

DO NOT SCALE

DIMENSIONS IN mm

METRIC

THIRD ANGLE
PROJECTION

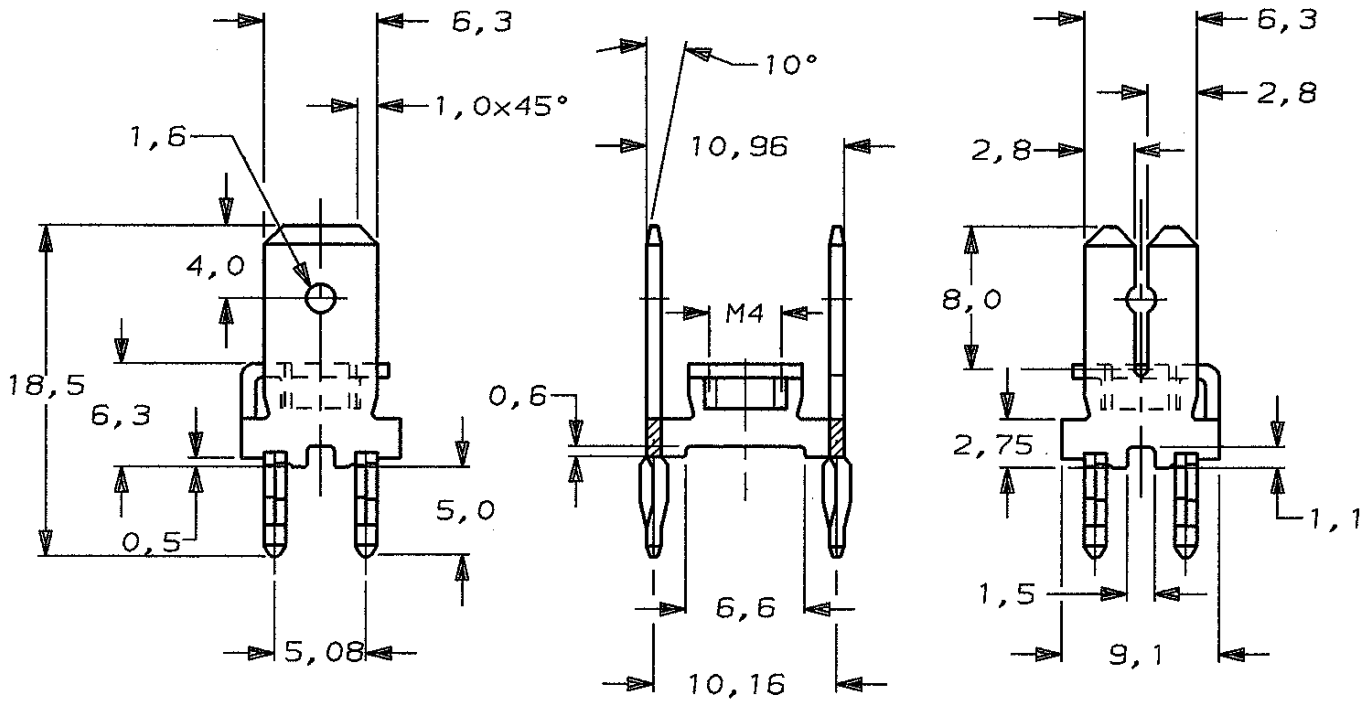

NOTES :

- 1 PLATING : 2,54 μ m SnPb (93/7) MIN. ALL OVER
UNDERLAYER 1,25 μ m Ni ALL OVER.
- 2 MATERIAL THICKNESS 0,8 mm .

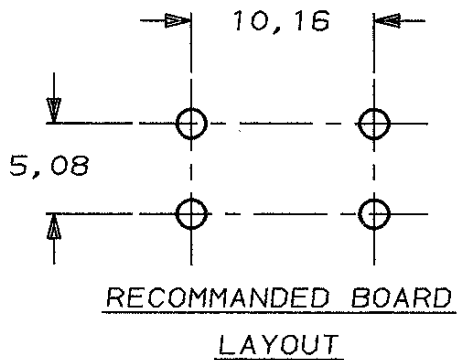

PLATED THROUGH HOLE SPECIFICATION	
DRILLED HOLE	1,6 \pm 0,025
Cu- THICKNESS	25-75 μ m
SnPb-THICKNESS	4-10 μ m
FINISHED HOLE	1,39 \pm 0,15
FINISHED HOLE (AFTER REFLOW)	1,36 \pm 0,18

1	PHOSPHORBRONZE	216905-1
FINISH	MATERIAL	PARTNUMBER

CUSTOMER DRAWING

AMP | AMP-HOLLAND B.V. 's-Hertogenbosch, The Netherlands.

THIS DRAWING IS UNPUBLISHED | RELEASED FOR PUBLICATION - , 19

© COPYRIGHT 19- BY AMP-HOLLAND B.V.
ALL INTERNATIONAL RIGHTS RESERVED.
AMP PRODUCTS MAY BE COVERED BY U.S. AND FOREIGN PATENTS AND/OR PATENTS PENDING.

FOR REFERENCE ONLY
WILL NOT BE UPDATED

DR. S.MEEUWSEN	DATE 15-02-90	WIRE RANGE -	NAME POWER TERMINAL FOR POSITIVE LOCK RECEPTACLE (1,6 P.C.BOARD THICKNESS)	REV. DATE D M Y 19 02 91
CHK. R.V.LOKVEN	DATE 03-04-90	INSUL. RANGE -	DWG. No. C-216905	REV. LTR. B
APP. L.V.SOEST	DATE 03-04-90	SIZE A4	SHEET 1 OF 1	