

4

3

2

1

THIS DRAWING IS UNPUBLISHED. RELEASED FOR PUBLICATION
 © COPYRIGHT - BY TYCO ELECTRONICS CORPORATION. ALL RIGHTS RESERVED.

LOC	DIST	REVISIONS			
P	LTR	DESCRIPTION	DATE	DWN	APVD
AF	50	A1	REL PER ECR 06-028712	08DEC06	JR KR

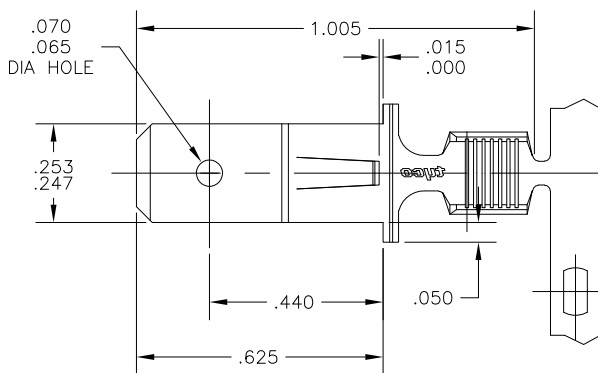

- CONTINUOUS STRIP ON REELS
- WIRE SIZE 7,000 - 13,000 CMA
- CRIMP INFO: .180 WIDTH, F TYPE
 CRIMP HT (±.002) = (TOTAL CMA + 22,200)/304,500

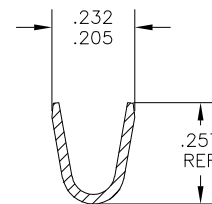
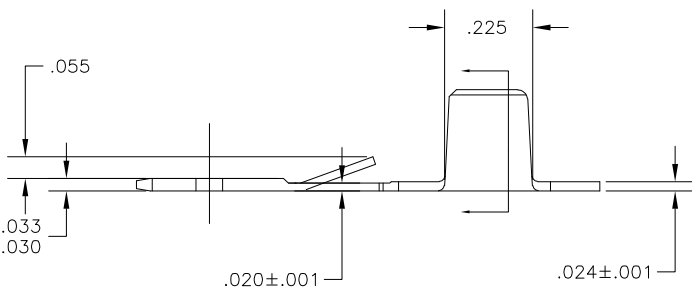

1742266-1

PART NO

THIS DRAWING IS A CONTROLLED DOCUMENT.		DWN jr_ruth 11APR05	Tyco Electronics Corporation Harrisburg, Pa 17105-3608	
DIMENSIONS: INCHES		CHK K RANDOLPH 11APR05	APVD K RANDOLPH 11APR05	
TOLERANCES UNLESS OTHERWISE SPECIFIED:		NAME TAB, FASTIN-FASTON, AMPLIVAR, .250 SERIES		
0 PLC ± -		PRODUCT SPEC		
1 PLC ± -		APPLICATION SPEC		
2 PLC ± -		114-2146		
3 PLC ± .010		SIZE CAGE CODE DRAWING NO		
4 PLC ± -		A3 00779 C-1742266		
ANGLES ± 5°		RESTRICTED TO		
MATERIAL 082 BRASS	FINISH .000080 MIN TIN	WEIGHT		—
CUSTOMER DRAWING		SCALE 4:1		SHEET 1 OF 1 REV A1

AMP 1470-19 REV 31MAR2000