

4

3

2

1

THIS DRAWING IS UNPUBLISHED. RELEASED FOR PUBLICATION  
 © COPYRIGHT - BY TYCO ELECTRONICS CORPORATION. ALL RIGHTS RESERVED.

LOC	DIST	REVISIONS			
P	LTR	DESCRIPTION	DATE	DWN	APVD
AF	50	A2	REL PER ECR 07-000181	09JAN07	JR KR

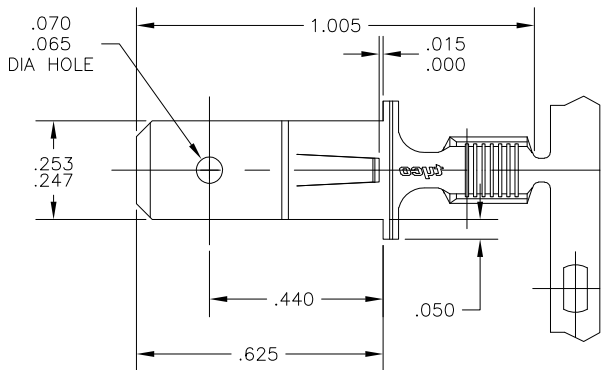

- CONTINUOUS STRIP ON REELS
- WIRE SIZE 3000 - 7000 CMA
- CRIMP INFO: WIDTH .140, F TYPE  
 CRIMP HT. ( $\pm .002$ ) = (TOTAL CMA + 17,000)/240,000

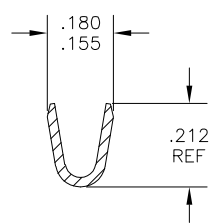
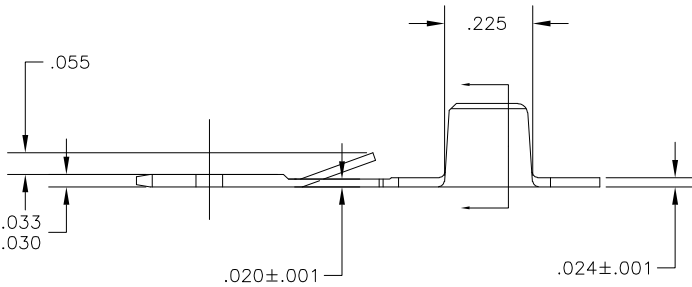

1742265-1  
 PART NO

THIS DRAWING IS A CONTROLLED DOCUMENT.		DWN jr_ruth 11APR05	Tyco Electronics Corporation Harrisburg, Pa 17105-3608	
DIMENSIONS: INCHES	TOLERANCES UNLESS OTHERWISE SPECIFIED:	CHK K RANDOLPH 11APR05	APVD K RANDOLPH 11APR05	
	0 PLC ± -	PRODUCT SPEC	NAME TAB, FASTIN-FASTON, AMPLIVAR, .250 SERIES	
	1 PLC ± -	APPLICATION SPEC	SIZE 114-2146	
	2 PLC ± -	WEIGHT	CAGE CODE A300779	DRAWING NO C-1742265
	3 PLC ± .010	CUSTOMER DRAWING	RESTRICTED TO	
	4 PLC ± -		SCALE 4:1	SHEET 1 OF 1
	ANGLES ± 5°		REV A2	
MATERIAL 082 BRASS	FINISH .000080 MIN TIN			

AMP 1470-19 REV 31MAR2000