

4

3

2

1

THIS DRAWING IS UNPUBLISHED. RELEASED FOR PUBLICATION .19
 © COPYRIGHT 19 BY AMP INCORPORATED. ALL RIGHTS RESERVED.

LOC	DIST	REVISIONS				
P	LTR	DESCRIPTION	DATE	DWN	APVD	
AF	50	B	REL PER 063A-0579-01	160CT01	JR	PD

- 1 CONTINUOUS STRIP ON REELS.
- 2 ACCEPTS MAGNET WIRE RANGES 24-20 AWG.
- 3 MATING TAB THK IS $.032 \pm .001$.

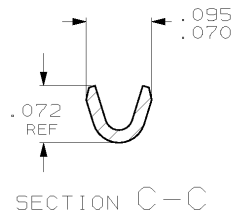
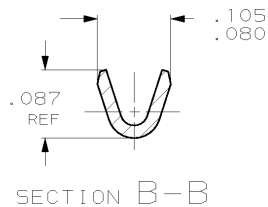
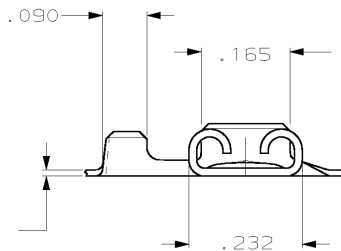
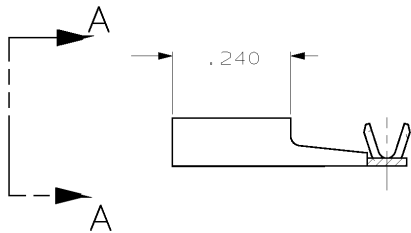
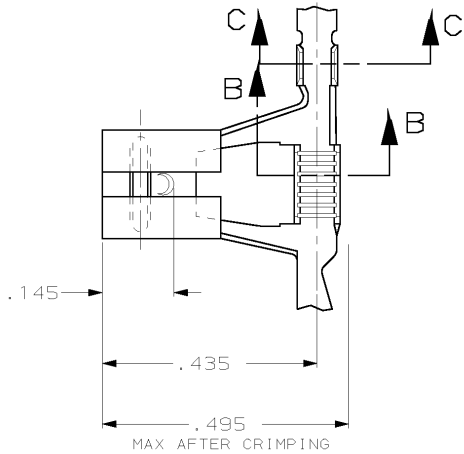

VIEW A-A

1217624-1
PART NO.

THIS DRAWING IS A CONTROLLED DOCUMENT.		DWN JR RUTH	OSAPROT	AMP AMP Incorporated Harrisburg, PA 17105-3608
DIMENSIONS: INCHES		CHK MS FEHER	OSAPROT	
TOLERANCES UNLESS OTHERWISE SPECIFIED:		APVD P. DESANTIS	OSAPROT	NAME RECEPTACLE, FASTON, FLAG, AMPLIVAR, .187 SERIES
0 PLC	±-	PRODUCT SPEC		SIZE A3
1 PLC	±-	APPLICATION SPEC		CAGE CODE 100779
2 PLC	±.010			DRAWING NO 1217624
3 PLC	±-			RESTRICTED TO
4 PLC	±-			
ANGLES	±-	WEIGHT		
MATERIAL 4M BRASS	FINISH .000080 MIN TIN	CUSTOMER DRAWING		SCALE 5:1

AMP 1470-19 REV 11 JUN 97

09-APR-01 08:46:01 amp13469 /ws/tesp/u.jr-proposals