

4

3

2

1

THIS DRAWING IS UNPUBLISHED.
DIFFUSION RESTREINTE AMP

RELEASED FOR PUBLICATION
LIBRE A LA DIFFUSION

© COPYRIGHT 20 BY TYCO ELECTRONICS CORPORATION. ALL RIGHTS RESERVED.
Tous droits réservés.

LOC	DIST	REVISIONS			
P	LTR	DESCRIPTION	DATE	DWN	APVD
REV	MOD	MODIFICATIONS		REVIS.	APP.
L		Redessine en CAO et revise EC 7462	31MAR98	O.L	-
M		CLARIFICATION	09OCT2000	JJD	-

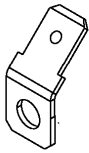
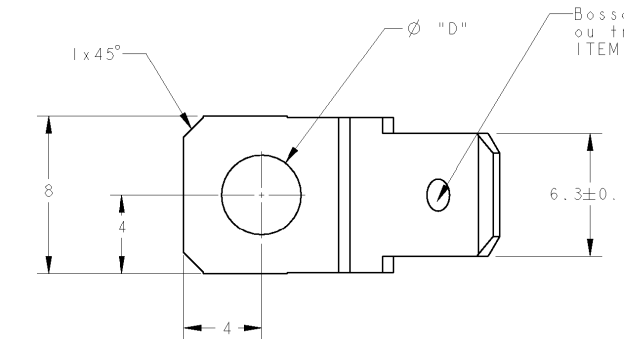

ECHELLE 2:1

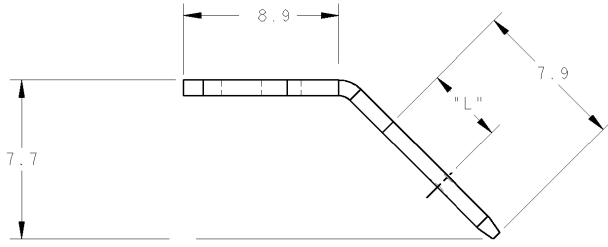

Reference	Finition	"L"	"D"	"d"
141158-1	dore	4.1	3	bossage
141036-1	brut	3.4	5.2	trou
140829-2	etame	3.4	3	trou
140829-1	brut	3.4	3	trou
140814-2	etame	3.4	4.1	trou
140814-1	brut	3.4	4.1	trou
140856-2	etame	4.1	3.7	bossage
140856-1	brut	4.1	3.7	bossage
140759-1	nickelle	4.1	5.2	bossage
140759-0	etame	4.1	5.2	bossage
140665-0	brut	4.1	5.2	bossage
140660-0	etame	4.1	3	bossage
140659-0	brut	4.1	3	bossage
140598-0	etame	4.1	4.1	bossage
140597-0	brut	4.1	4.1	bossage

<small>THIS DRAWING IS A CONTROLLED DOCUMENT FOR TYCO ELECTRONICS CORPORATION IT IS SUBJECT TO CHANGE AND THE CONTROLLING ENGINEERING ORGANIZATION SHOULD BE CONTACTED FOR THE LATEST REVISION. CE PLAN EST UN DOCUMENT CONTROLÉ PAR AMP INCORPORATED IL EST SUSCEPTIBLE D'ÊTRE REVISÉ. CONTACTER LE SERVICE TECHNIQUE D'AMP DE FRANCE POUR OBTENIR LA DERNIÈRE RÉVISION.</small>		DWN/DESSINE 30MANS98 O. LEMPEREUR CHR/VERIFIE G. ROBERT APVD/APPROUVE Y. PETRONIN		NAME/TITRE AMP DE FRANCE 95301 PONTOISE	
DIMENSIONS: mm		TOLERANCES UNLESS OTHERWISE SPECIFIED TOLERANCES NON SPECIFIEES S'ILY A DE DECIMALES): 0. PLC/DEC: ±0.2 2. PLC/DEC: ± 3. PLC/DEC: ± 4. PLC/DEC: ± ANGLES ±30°		PRODUCT SPEC SPEC. PRODUIT APPLICATION SPEC SPEC. APPLICATION WEIGHT MASSE APPROX.	
MATERIAL/MATIERE LAITON		FINISH/FINITION Voir tableau		SIZE/FORMAT A3 CAGE CODE 00779 DRAWING NO. H-PLAN 140597 RESTRICTED TO RESERVE A	
CUSTOMER DRAWING		/PLAN CLIENT		UNDOUMENT POUR REFERENCE	

AMP 1470-19 REV 31MAR2000

Prof/ENGINEER DRAWING