

MATERIAL NUMBER	ENG. NUMBER	TAPE MATERIAL NUMBER	TAPE ENG NUMBER	WIRE SIZE AWG	WIRE SIZE MM SQ.	NYLON COLOR	B MAX.	D MWID (E1)	E MIN. DIA.	F MAX. DIA.	H (E1) NOMINAL
191640015	SAA-9260	191640016	SAA-9260T	22-18	.25-1.5	RED	.45/11.4	.17/4.3	.049/1.25	.29/7.4	.47/12.0
191640048	SBB-9262	191640049	SBB-9262T	16-14	1.0-2.5	BLUE	.45/11.4	.18/4.5	.082/2.08	.31/7.9	.47/12.0
191640075	SC-9280	N/A	N/A	12-10	4.0-6.0	YELLOW	.46/11.7	.23/5.8	.148/3.76	.39/9.9	N/A

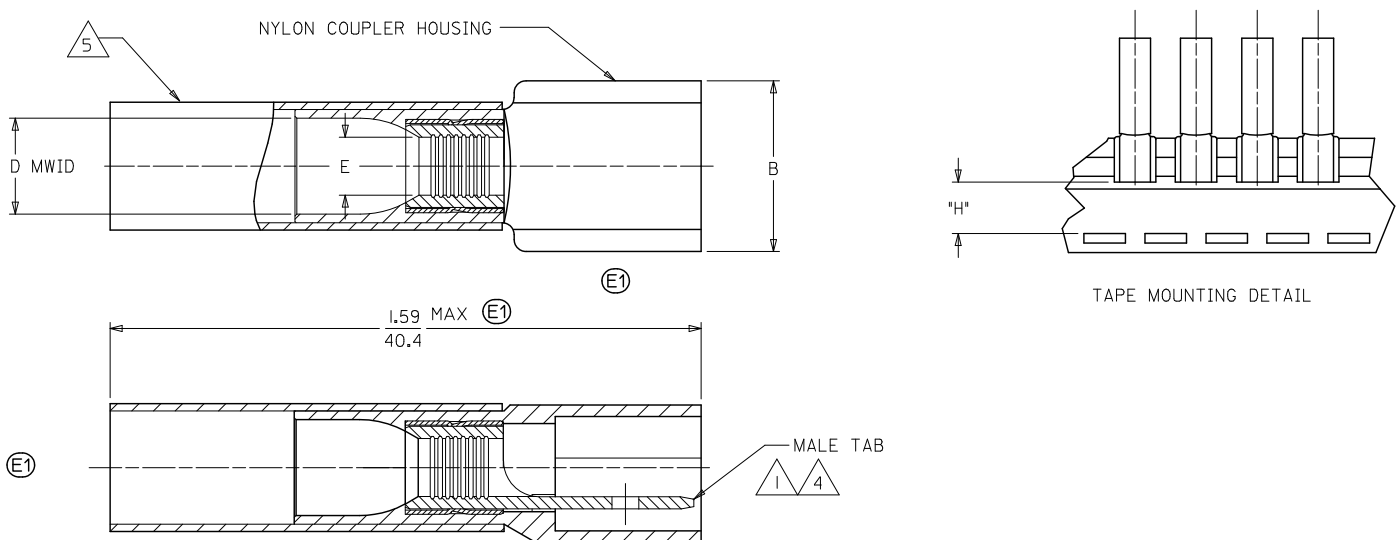

- NOTES:
- (E1) 1. MALE TAB CONFORMS TO UL310.
 - 2. ALL DIMENSIONS SHOWN ARE BEFORE SHRINK TUBING IS HEATED.
 - 3. "MWID" DENOTES MAX. WIRE INSULATION DIA.
 - (E1) 4. TAB MATERIAL: COPPER ALLOY, PLATING: TIN
 - (E1) 5. NYLON HEAT SHRINKABLE TUBING WITH HOTMELT INNER LINER. SEE CHART FOR COLOR.
 - (E1) 6. ALL PARTS ARE ROHS COMPLIANT.

SALES DRAWING

CORRECT SPECS EC NO: WNAZ010-0115 DRAWN: THRODAHL 2010/02/16 CHKD: JMACNEIL 2010/02/18 APPR: JMACNEIL 2010/02/22 DESCRIPTION	QUALITY SYMBOLS	GENERAL TOLERANCES (UNLESS SPECIFIED)	DIMENSION STYLE IN/MM	SCALE ---	DESIGN UNITS INCH	THIRD ANGLE PROJECTION
	▽=0	4 PLACES ± --- ± ---	DRAWN BY BRE	DATE 2002/10/25	TITLE PERMA-SEAL COUPLER MALE TAB TERMINAL	
	▽=0	3 PLACES ± --- ± ---	CHECKED BY HEB	DATE 2002/10/25	MOLEX INCORPORATED	
		2 PLACES ± --- ± ---	APPROVED BY RWD	DATE 2002/10/25	MATERIAL NO. SEE CHART	DOCUMENT NO. SD-19164-039
		1 PLACE ± --- ± ---	ANGULAR ± ---°		THIS DRAWING CONTAINS INFORMATION THAT IS PROPRIETARY TO MOLEX INCORPORATED AND SHOULD NOT BE USED WITHOUT WRITTEN PERMISSION	
		DRAFT WHERE APPLICABLE MUST REMAIN WITHIN DIMENSIONS				