

MATERIAL NUMBER	ENGINEERING NUMBER	TAPE MATERIAL NUMBER	TAPE ENGINEERING NUMBER	WIRE SIZE AWG	WIRE SIZE MM SQ.	FITS MALE TAB	PERMA-SEAL COLOR	Ⓢ A MAX.	Ⓢ D MWID	E Ⓢ MIN	H NOMINAL
191640017	SAA-9261	191640018	SAA-9261T	22-18	.25-1.5	.250 X .032	RED	1.50/38.1	.17/4.3	.081/2.05	.55/14.0
191640050	SBB-9263	191640051	SBB-9263T	16-14	1.0-2.5	.250 X .032	BLUE	1.50/38.1	.18/4.5	.081/2.05	.55/14.0
191640076	SC-9281	191640305	SC-9281T	12-10	4.0-6.0	.250 X .032	YELLOW	1.52/38.6	.23/5.8	.140/3.56	.56/14.2

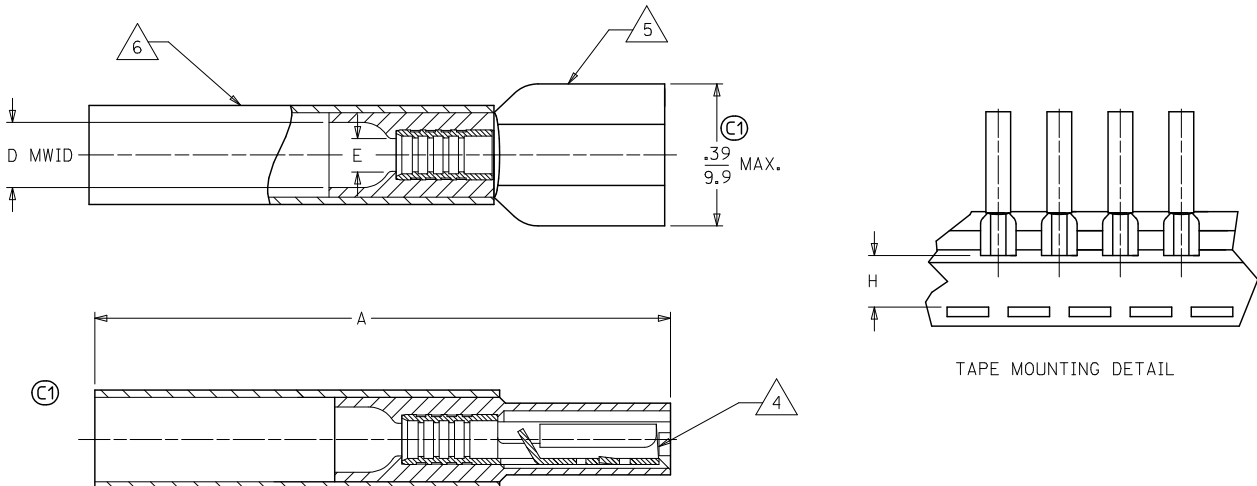

- NOTES:
- Ⓢ 1. FEMALE RECEPTACLE CONFORMS TO UL310.
 - 2. ALL DIMENSIONS SHOWN ARE BEFORE SHRINK TUBING IS HEATED.
 - 3. *MWID* DENOTES MAX. WIRE INSULATION DIA.
 - Ⓢ 4. TAB MATERIAL: .018 THK, BRASS, PLATING, TIN.
 - Ⓢ 5. INSULATION MAT'L: MOLDED NYLON
 - Ⓢ 6. NYLON TUBING WITH HOTMELT INNER LINER. SEE CHART FOR COLOR.
 - Ⓢ 7. ALL PARTS ARE ROHS COMPLIANT.

CORRECT SPECS EC NO: WNAZ010-0115 DRAWN BY: THRODAHL 2010/02/16 CHKD: JMACNEIL 2010/02/18 APPR: JMACNEIL 2010/02/22 DESCRIPTION	QUALITY SYMBOLS	GENERAL TOLERANCES (UNLESS SPECIFIED)	DIMENSION STYLE	SCALE	DESIGN UNITS	THIRD ANGLE PROJECTION
	▽=0 ▽=0	mm INCH 4 PLACES ± --- ± --- 3 PLACES ± --- ± --- 2 PLACES ± --- ± --- 1 PLACE ± --- ± --- ANGULAR ± ---°	IN/MM	---	INCH	DRAWN BY: BRE DATE: 2002/10/29 CHECKED BY: HEB DATE: 2002/10/29 APPROVED BY: RWD DATE: 2002/10/29
	DRAFT WHERE APPLICABLE MUST REMAIN WITHIN DIMENSIONS	SEE CHART	TITLE	PERMA-SEAL COUPLER FEMALE RECEPTACLE		
			MATERIAL NO.	DOCUMENT NO.	SHEET NO.	