

MATERIAL NUMBER	ENGINEERING NUMBER	TAPE MATERIAL NUMBER	TAPE ENGINEERING NUMBER	WIRE SIZE AWG	WIRE SIZE MM SQ.	FITS MALE TAB	PERMA-SEAL COLOR	Ⓢ A MAX.	Ⓢ D MWID	E Ⓢ MIN	H NOMINAL
191640017	SAA-9261	191640018	SAA-9261T	22-18	.25-1.5	.250 X .032	RED	1.50/38.1	.17/4.3	.081/2.05	.55/14.0
191640050	SBB-9263	191640051	SBB-9263T	16-14	1.0-2.5	.250 X .032	BLUE	1.50/38.1	.18/4.5	.081/2.05	.55/14.0
191640076	SC-9281	191640305	SC-9281T	12-10	4.0-6.0	.250 X .032	YELLOW	1.52/38.6	.23/5.8	.140/3.56	.56/14.2

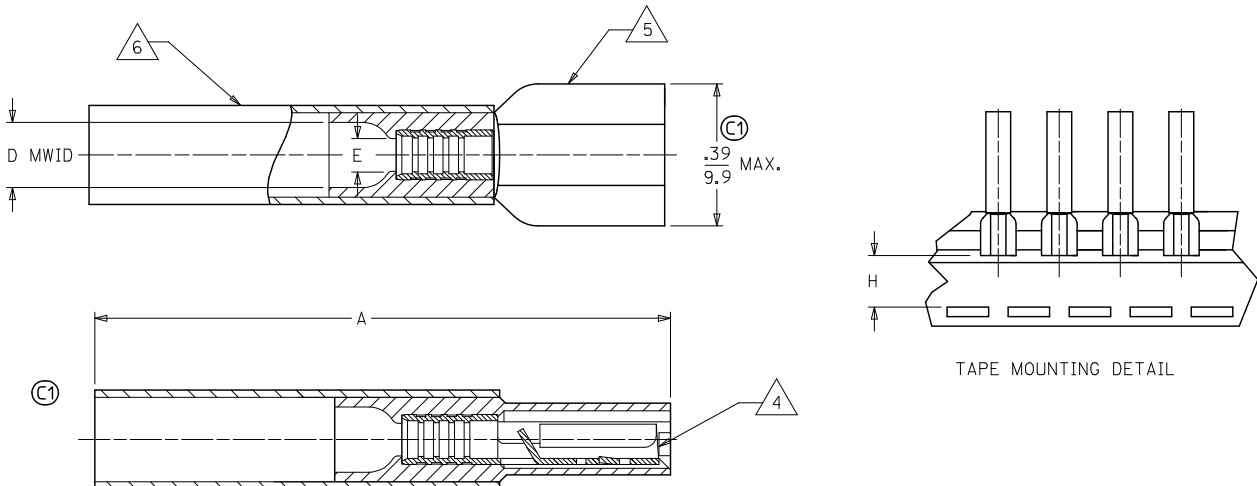

- NOTES:
- Ⓢ 1. FEMALE RECEPTACLE CONFORMS TO UL310.
 - 2. ALL DIMENSIONS SHOWN ARE BEFORE SHRINK TUBING IS HEATED.
 - 3. *MWID* DENOTES MAX. WIRE INSULATION DIA.
 - Ⓢ 4. TAB MATERIAL: .018 THK, BRASS, PLATING, TIN.
 - Ⓢ 5. INSULATION MAT'L: MOLDED NYLON
 - Ⓢ 6. NYLON TUBING WITH HOTMELT INNER LINER. SEE CHART FOR COLOR.
 - Ⓢ 7. ALL PARTS ARE ROHS COMPLIANT.

CORRECT SPECS EC NO: WNAZ010-0115 DRAWN BY: THRODAHL 2010/02/16 CHKD: JMACNEIL 2010/02/18 APPR: JMACNEIL 2010/02/22 DESCRIPTION	QUALITY SYMBOLS	GENERAL TOLERANCES (UNLESS SPECIFIED) mm INCH 4 PLACES ± --- ± --- 3 PLACES ± --- ± --- 2 PLACES ± --- ± --- 1 PLACE ± --- ± --- ANGULAR ± ---° DRAFT WHERE APPLICABLE MUST REMAIN WITHIN DIMENSIONS	DIMENSION STYLE	SCALE	DESIGN UNITS	THIRD ANGLE PROJECTION PERMA-SEAL COUPLER FEMALE RECEPTACLE MOLEX INCORPORATED SD-19164-020 SHEET NO. 1 OF 1
	▽=0 ▽=0		IN/MM	---	INCH	
			DRAWN BY	DATE	TITLE	
			CHECKED BY	DATE		
		APPROVED BY	DATE			
		MATERIAL NO.	SEE CHART	DOCUMENT NO.		
		THIS DRAWING CONTAINS INFORMATION THAT IS PROPRIETARY TO MOLEX INCORPORATED AND SHOULD NOT BE USED WITHOUT WRITTEN PERMISSION				