

4

3

2

1

THIS DRAWING IS UNPUBLISHED. RELEASED FOR PUBLICATION
 © COPYRIGHT - By - ALL RIGHTS RESERVED.

LOC	DIST	REVISIONS			
P	LTR	DESCRIPTION	DATE	DWN	APVD
AF	50				
		K1 REVISED PER ECO-11-004917	11MAR11	RK	HMR

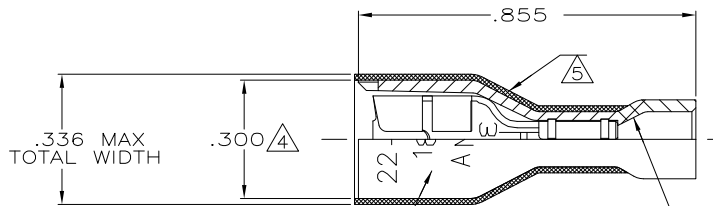

- 1 MATES WITH .032±.001x.187 TAB
- 2 WIRE STRIP LENGTH .281
- 3 INSULATION SIZE .060-.135 DIA
- 4 DIMENSION DOES NOT INCLUDE TRIM BURR
- 5 .015 MAX CARRIER TRIM BURR PER SIDE IS ALLOWABLE IN THE SHADED AREA

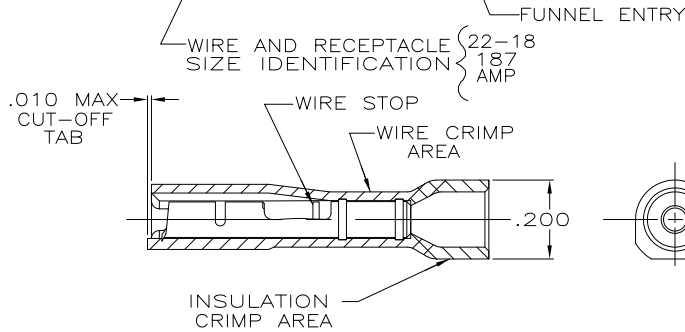
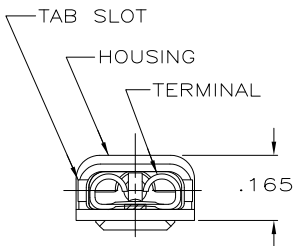

HOUSING: NYLON, COLOR-RED TRANSLUCENT	2-520411-2
RECEPTACLE: #3 HARD BRASS TIN PL .000080 MIN THK	

MATERIAL & FINISH PART NO

THIS DRAWING IS A CONTROLLED DOCUMENT.		DWN P FORTNEY 10/31/88	TE Connectivity	
DIMENSIONS: INCHES		CHK MS FEHER 11/4/88		
TOLERANCES UNLESS OTHERWISE SPECIFIED:		APVD K RANDOLPH 11/4/88	NAME	
0 PLC ± -		PRODUCT SPEC	RECEPTACLE ASSY, ULTRA-FAST PLUS, LOOSE PIECE, 187 SERIES, 22-18 AWG	
1 PLC ± -		108-2044	SIZE	
2 PLC ± -		APPLICATION SPEC	CAGE CODE	
3 PLC ± .015		114-2123	DRAWING NO	
4 PLC ± -	FINISH	WEIGHT	RESTRICTED TO	
ANGLES ± -	SEE TABLE	-	A3 00779 C-520411	
MATERIAL		CUSTOMER DRAWING		SCALE 4:1
SEE TABLE		SHEET 1 OF 1		REV K1