

DRAWING MADE IN THIRD ANGLE PROJECTION

THIS DRAWING IS UNPUBLISHED. RELEASED FOR PUBLICATION .19
 © COPYRIGHT 19 BY AMP INCORPORATED, HARRISBURG, PA. ALL INTERNATIONAL RIGHTS RESERVED. AMP PRODUCTS MAY BE COVERED BY U.S. AND FOREIGN PATENTS AND/OR PATENTS PENDING.

LOC		DIST		REV		ZONE		LTR		REVISIONS		DATE	APPROVED
AF	50	P	F							F	REV PER 063A-0081-99	8AUG99	JR/JH

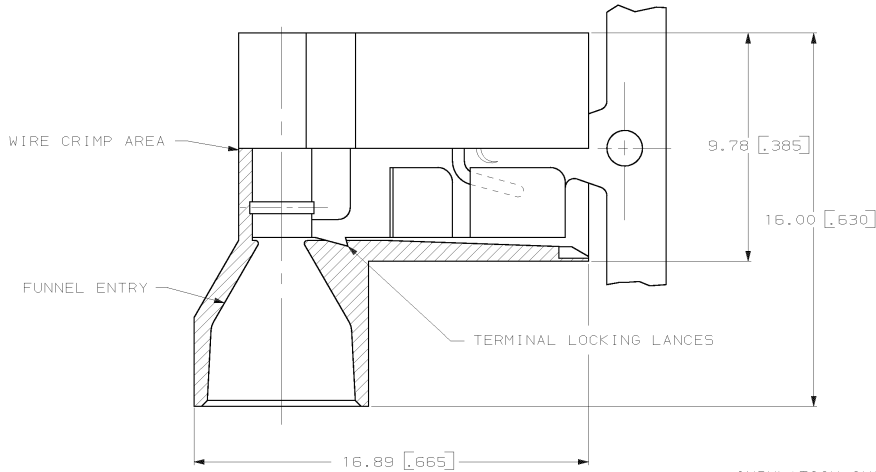

- 1 - FITS 0.81 ±0.025 X 6.35 [.032 ±.001 X .250] TAB
- 2 - WIRE SIZE: 0.3 - 0.9mm² [22-18 AWG] (STRANDED ONLY)
 STRIP LENGTH: ONE WIRE 7.94 [.312]
 TWO WIRES 8.51 [.335]
- 3 - INSULATION SIZE: 5.84 [.230] MAX DIA.
- 4 - DIMENSIONS IN BRACKETS ARE IN INCHES OR AWG.
- 5 - REFER TO PRODUCT SPEC 108-2043 FOR PERFORMANCE DATA.
- 6 - CONTINUOUS STRIP

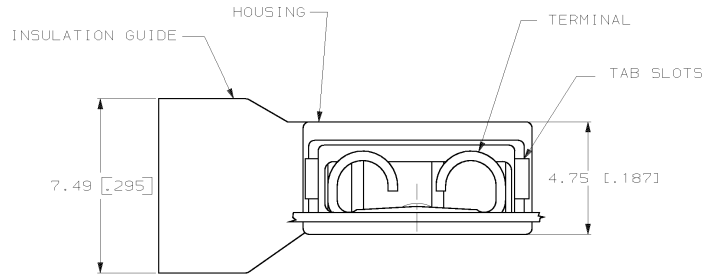
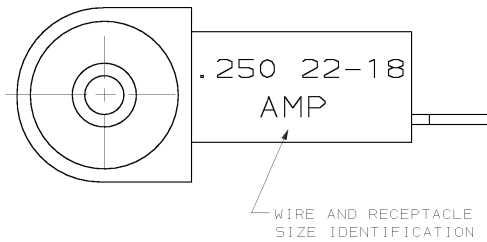

RED TRANSLUCENT		6/6 NYLON	TIN	.016 BRASS	2-520856-2	
FINISH	HOUSING	MATERIAL	FINISH	TERMINAL	MATERIAL	PART NO
UNLESS OTHERWISE SPECIFIED DIMENSIONS ARE IN INCHES mm		DR 8/25/86 JR RUTH		AMP INCORPORATED Harrisburg, Pa. 17105		NAME .250 SERIES ULTRA-FAST FLAG RECEPTACLE ASS'Y
TOLERANCES ON :		CHK 8/25/86 G YETTER		SIZE FSCM NO DRAWING NO		
2 PL DEC ± -		APPD 9/2/86 K RANDOLPH		C 00779 520856		SCALE NTS SHEET 1 OF 1
3 PL DEC ± 0.38 [.015]		MATERIAL SEE ABOVE		PRODUCT SPEC 108-2043		
ANGLES ± -		FINISH SEE ABOVE		APPLICATION SPEC 114-2123		
				WEIGHT		

METRIC