

4

3

2

1

THIS DRAWING IS UNPUBLISHED. RELEASED FOR PUBLICATION  
 © COPYRIGHT - By - ALL RIGHTS RESERVED.

LOC	DIST	REVISIONS			
P	LTR	DESCRIPTION	DATE	DWN	APVD
AF	50	N1	REVISED PER ECO-11-005027	11MAR11	RK HMR

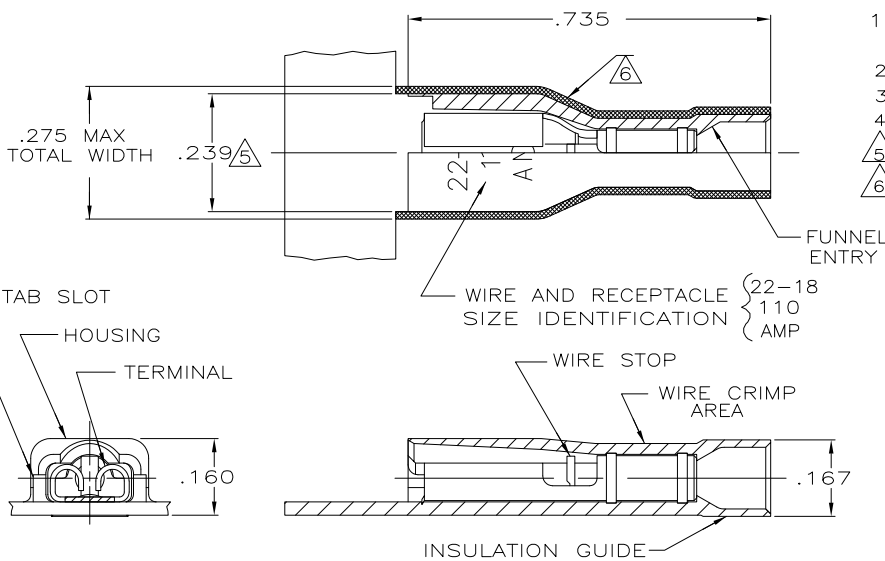

- 1 MATES WITH .016±.001X.110 OR .125 TAB
- 2 WIRE STRIP LENGTH .281
- 3 INSULATION SIZE .120 MAX DIA
- 4 CONTINUOUS STRIP ON REELS
- 5 DIMENSION DOES NOT INCLUDE TRIM BURR
- 6 .015 MAX CARRIER TRIM BURR PER SIDE IS ALLOWABLE IN THE SHADED AREA

HOUSING: NYLON, COLOR-RED TRANSLUCENT	2-520080-2
RECEPTACLE: #3 HARD BRASS TIN PL .000080 MIN THK	
MATERIAL & FINISH	PART NO

THIS DRAWING IS A CONTROLLED DOCUMENT.		DWN	P FORTNEY	11/8/88	<b>STE</b> TE Connectivity
DIMENSIONS: INCHES		CHK	MS FEHER	11/8/88	
TOLERANCES UNLESS OTHERWISE SPECIFIED:		APVD	K RANDOLPH	11/10/88	NAME
0 PLC	± -	PRODUCT SPEC		RECEPTACLE ASSY, ULTRA-FAST, .110/.125 SERIES, 22-18AWG	
1 PLC	± -	APPLICATION SPEC		108-2043	
2 PLC	± -	WEIGHT		114-2123	
3 PLC	± .015	SIZE	A3	CAGE CODE	00779
4 PLC	± -	DRAWING NO	C=520080		RESTRICTED TO
ANGLES	± -	CUSTOMER DRAWING		SCALE	5:1
MATERIAL	SEE TABLE	FINISH		SHEET	1 OF 1
				REV	N1