

4

3

2

1

THIS DRAWING IS UNPUBLISHED. RELEASED FOR PUBLICATION
 © COPYRIGHT - BY TYCO ELECTRONICS CORPORATION. ALL INTERNATIONAL RIGHTS RESERVED.

LOC	DIST	REVISIONS				
P	LTR	DESCRIPTION	DATE	DWN	APVD	
AF	50	M1	REVISED PER ECR-09-026241	16DEC09	HMR GP	

- 1 MATES WITH .032±.001x.187 TAB
- 2 WIRE STRIP LENGTH .281
- 3 INSULATION SIZE .160 MAX DIA
- 4 CONTINUOUS STRIP ON REELS
- △5 DIMENSION DOES NOT INCLUDE TRIM BURR
- △6 .015 MAX CARRIER TRIM BURR PER SIDE IS ALLOWABLE IN THE SHADED AREA

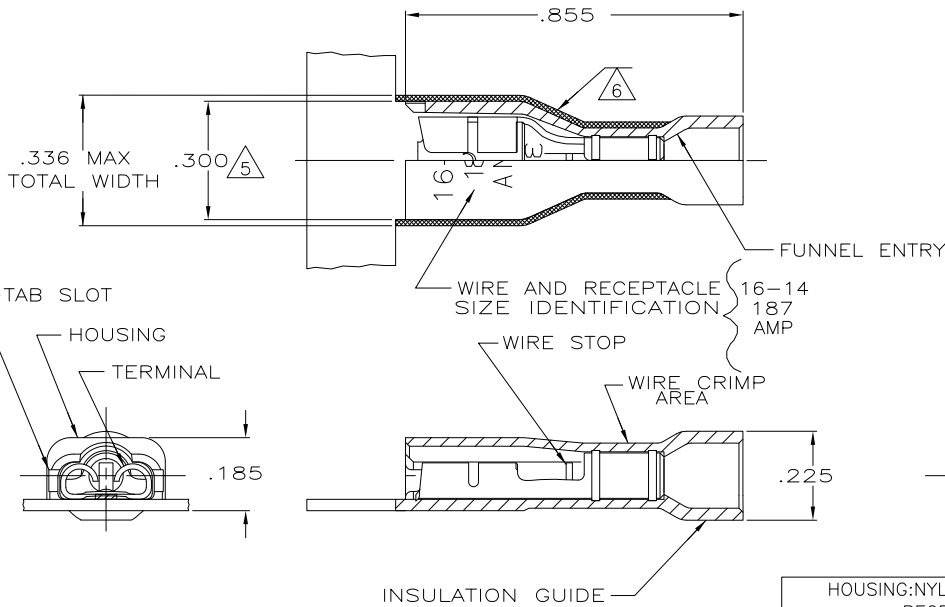

HOUSING: NYLON, COLOR-BLACK TRANSLUCENT RECEPTACLE: #3 HARD BRASS TIN PL .000080 MIN THK	9-520124-2
HOUSING: NYLON, COLOR-BLUE TRANSLUCENT RECEPTACLE: #3 HARD BRASS TIN PL .000080 MIN THK	3-520124-2
MATERIAL & FINISH	PART NO

THIS DRAWING IS A CONTROLLED DOCUMENT.		DWN P FORTNEY 11/7/88	Tyco Electronics Corporation Harrisburg, PA 17105-3608	
DIMENSIONS: INCHES	TOLERANCES UNLESS OTHERWISE SPECIFIED:	CHK MS FEHER 11/8/88	NAME K RANDOLPH 11/8/88	
0 PLC ± -	1 PLC ± -	PRODUCT SPEC 108-2043		
2 PLC ± -	3 PLC ± .015	APPLICATION SPEC 114-2123		
4 PLC ± -	ANGLES ± -	WEIGHT -	SIZE A3	CAGE CODE 00779
MATERIAL SEE TABLE	FINISH SEE TABLE	DRAWING NO C-520124	RESTRICTED TO -	CUSTOMER DRAWING
SCALE 4:1			SHEET 1 OF 1	REV M1