

DRAWING MADE IN THIRD ANGLE PROJECTION

THIS DRAWING IS UNPUBLISHED. RELEASED FOR PUBLICATION, 19 .

© COPYRIGHT 19 BY AMP INCORPORATED. ALL INTERNATIONAL RIGHTS RESERVED.

LOC	DIST	REVISIONS				DATE	APPD
P	F	ZONE	LTR	DESCRIPTION			
AF	50		H	REV PER 0250-94	5/27/94	JR/CM	

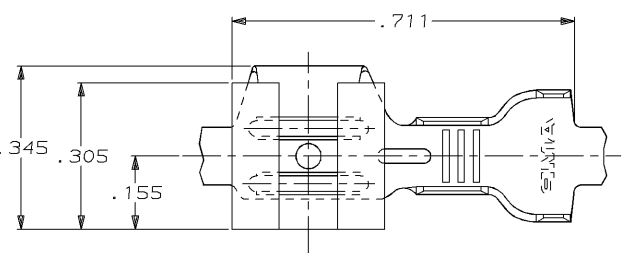

1 CONTINUOUS STRIP ON REELS.  
 2 TIN PLATE .000080 MIN THK

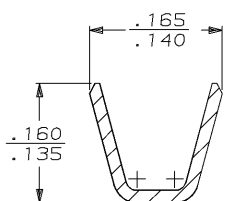
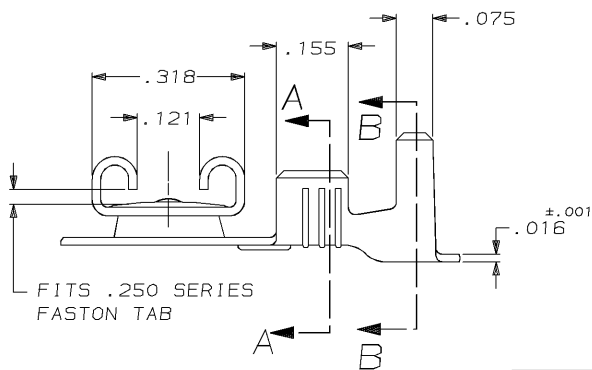

SECTION A-A  
SCALE 8:1

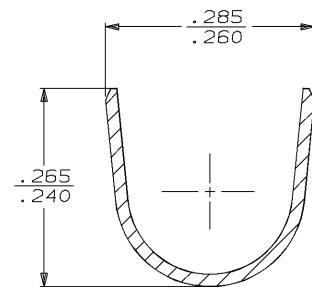

SECTION B-B  
SCALE 8:1

OBSOLETE	TIN	△	.170-.220	18-14	.032	60764-2
		-	.170-.220	18-14	.032	60764-1
	FINISH		INSUL RANGE	WIRE SIZE	MATING TAB THK ±.001	PART NO
DO NOT SCALE PRINT. UNLESS SPECIFIED DIMENSIONS ARE IN INCHES TOLERANCES ON:		DR 2/28/90 JR RUTH		AMP INCORPORATED Harrisburg, Pa. 17105		
2 PLC DEC ± .015		CHK 2/28/90 NS FEHER				
ANGLES ± -		APPD 2/28/90 C NEVERS		NAME RECEPTACLE, FASTON™ FLAG, REVERSIBLE, .250 SERIES		
MATERIAL 4M BRASS		APPD 2/28/90 R KUZO		SIZE B		
FINISH SEE TABLE		APPLICATION SPEC 114-2032		CAGE CODE 00779		
		WEIGHT -		DRAWING NO 60764		
				SCALE 5:1		SHEET 1 OF 1

AMP 1470-15 REV 6-89  
 27-MAY-94 08:31:39 amp13469 /files/dept2121/dwg2121/u.reversible

CUSTOMER DRAWING