

DRAWING MADE IN THIRD ANGLE PROJECTION

THIS DRAWING IS UNPUBLISHED. RELEASED FOR PUBLICATION, 19 .

© COPYRIGHT 19 BY AMP INCORPORATED. ALL INTERNATIONAL RIGHTS RESERVED.

LOC	DIST	REVISIONS				DATE	APPD
P	F	ZONE	LTR	DESCRIPTION			
AF	50		F	REV PER 0250-94	5/27/94	JR/CM	

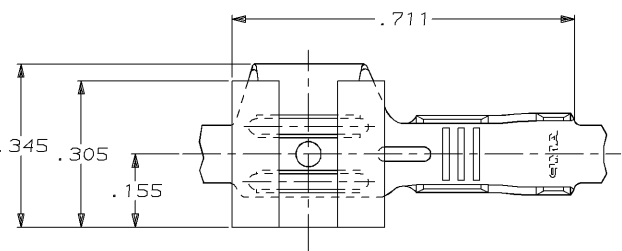

1 CONTINUOUS STRIP ON REELS.
 2 TIN PLATE .000080 MIN THK

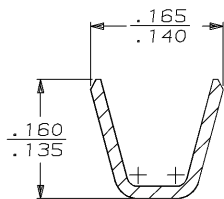
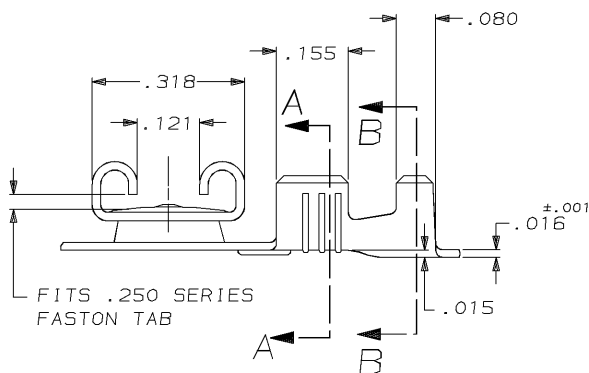

SECTION A-A
SCALE 8:1

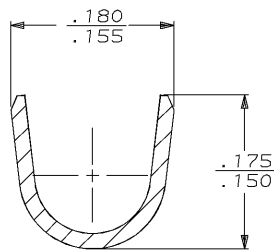

SECTION B-B
SCALE 10:1

TIN	INSUL	RANGE	WIRE SIZE	MATING TAB THK	PART NO
△		.090-.130	18-14	.032	62048-2
-		.090-.130	18-14	.032	62048-1

<small>DO NOT SCALE PRINT. UNLESS SPECIFIED DIMENSIONS ARE IN INCHES TOLERANCES ON: 2 PLC DEC ± 3 PLC DEC ± .015 ANGLES ±</small>	DR 6/7/91	AMP AMP INCORPORATED Harrisburg, Pa. 17105	NAME RECEPTACLE, FASTON™ FLAG, REVERSIBLE, .250 SERIES	
	CHK 6/7/91			
	APPD 6/7/91			
	APPD 6/7/91			
MATERIAL	PRODUCT SPEC	SIZE	CAGE CODE	DRAWING NO
4M BRASS	-	B	00779	62048
FINISH	APPLICATION SPEC	SCALE	SHEET	
SEE TABLE	114-2032	5:1	1 OF 1	
WEIGHT	-			