

4

3

2

1

THIS DRAWING IS UNPUBLISHED. RELEASED FOR PUBLICATION
 © COPYRIGHT - By - ALL RIGHTS RESERVED.

LOC	DIST	REVISIONS			
P	LTR	DESCRIPTION	DATE	DWN	APVD
	AF 50				
	C1	REVISED PER ECO-11-004917	11MAR11	RK	HMR

1 CONTINUOUS STRIP ON REELS

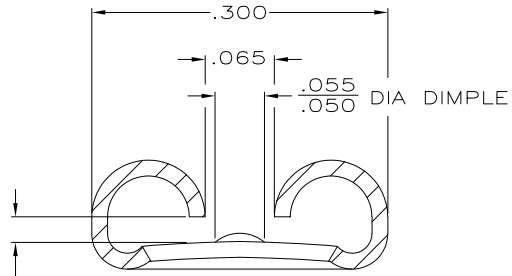
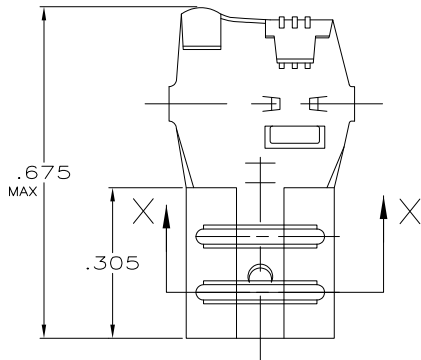

FITS .250 SERIES FASTON TABS

SECTION X-X
SCALE 10:1

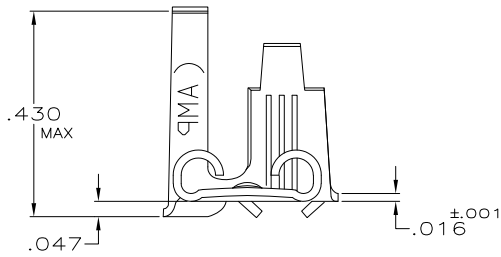

.110-.210 DIA	#18-#12 AWG	.032	42404-1
INSUL RANGE	WIRE SIZE	MATING TAB THK ±.001	PART NO

THIS DRAWING IS A CONTROLLED DOCUMENT.		DWN JR RUTH 4/5/91	STE TE Connectivity	
DIMENSIONS: INCHES		CHK MS FEHER 4/5/91		
TOLERANCES UNLESS OTHERWISE SPECIFIED:		APVD C MEYERS 4/5/91	NAME	
0 PLC ± -		PRODUCT SPEC	RECEPTACLE, FLAG, FASTON, .250 SERIES	
1 PLC ± -		APPLICATION SPEC	RESTRICTED TO	
2 PLC ± -		WEIGHT	SIZE A3	CAGE CODE 00779
3 PLC ± .010			DRAWING NO C-42404	
4 PLC ± -				
ANGLES ± -				
MATERIAL T2 STEEL	FINISH NICKEL	CUSTOMER DRAWING		SCALE 5:1 SHEET 1 OF 1 REV C1