

4

3

2

1

THIS DRAWING IS UNPUBLISHED. RELEASED FOR PUBLICATION
 © COPYRIGHT - By - ALL RIGHTS RESERVED.

LOC		DIST		REVISIONS			
P	LTR	DESCRIPTION		DATE	DWN	APVD	
AF	50	Z2	REVISED PER ECO-11-004820		11MAR11	RK	HMR

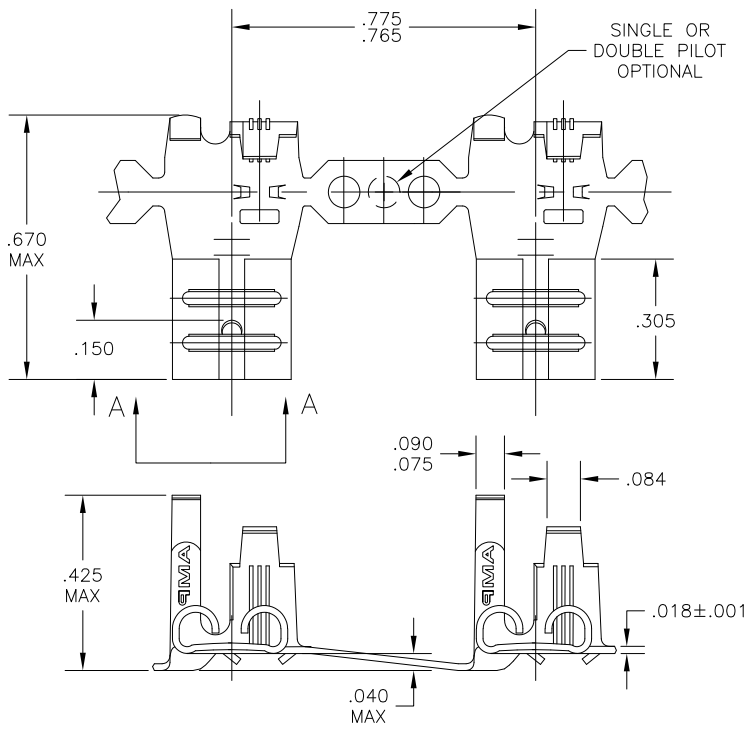

- 1 CONTINUOUS STRIP ON REELS
- 2 MATING TAB THK IS .032±.001.
- 3 WIRE SIZE IS #18-#12 AWG
- 4 INSULATION RANGE IS .110-.210 DIA.

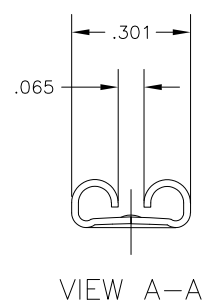

NICKEL	#2H STEEL	41531-1
-	4M BRASS	41531
FINISH	MATERIAL	PART NO.

THIS DRAWING IS A CONTROLLED DOCUMENT.

DIMENSIONS: INCHES	TOLERANCES UNLESS OTHERWISE SPECIFIED:	DWN JR RUTH 18OCT02	18OCT02					
	0 PLC ± -	CHK P DESANTIS 18OCT02	TE Connectivity					
	1 PLC ± -	APVD P DESANTIS 18OCT02	NAME					
	2 PLC ± -	PRODUCT SPEC	RECEPTACLE, FLAG, FASTON, .250 SERIES					
	3 PLC ± .015	APPLICATION SPEC	SIZE CAGE CODE DRAWING NO RESTRICTED TO					
4 PLC ± -	ANGLES ± -	WEIGHT	A3	00779	C-41531	-		
MATERIAL SEE TABLE	FINISH SEE TABLE	CUSTOMER DRAWING	SCALE	4:1	SHEET	1 of 1	REV	72