

THIS DRAWING IS UNPUBLISHED. RELEASED FOR PUBLICATION  
 © COPYRIGHT - By - ALL RIGHTS RESERVED.

LOC	DIST	REVISIONS					
AF	50	P	LTR	DESCRIPTION	DATE	DWN	APVD
		P2		REVISED PER ECO-11-004587	11MAR11	RK	HMR

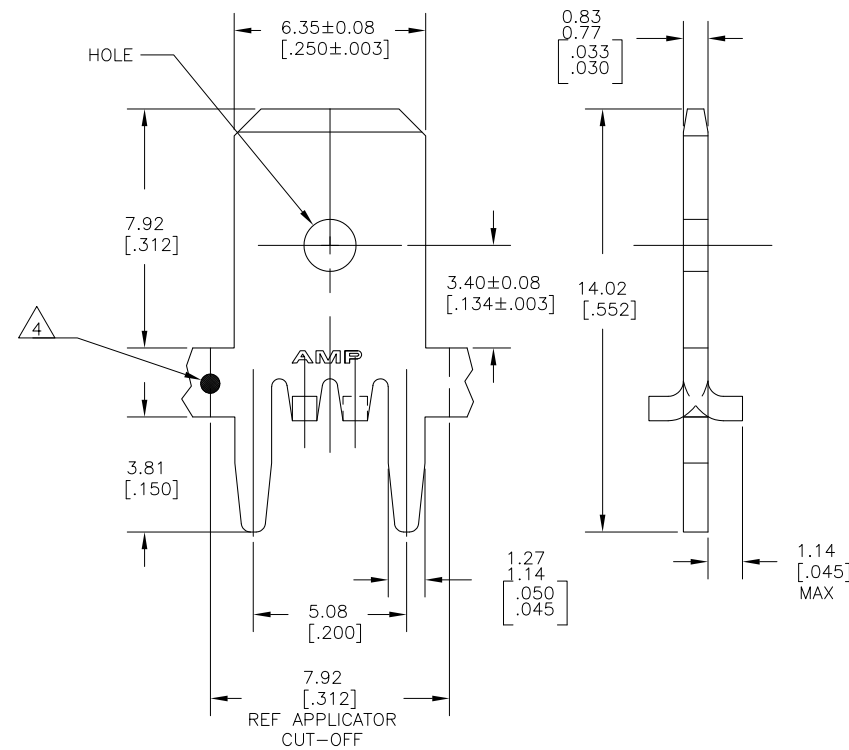

- 1 CONTINUOUS STRIP ON REELS.
- △2 TIN PLATE 0.00381 [.000150] MIN OVER 0.00254 [.000100] MIN THK COPPER OR TIN PLATE 0.00381 [.000150] MIN OVER 0.00127 [.000050] MIN THK NICKEL.
- △3 PRELIMINARY - NOT FOR PRODUCTION
- △4 OPTIONAL ID MARK, LOCATED APPROX AS SHOWN.

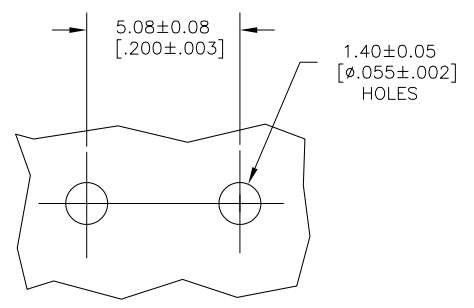

P.C. BOARD HOLE PATTERN

REVERSE	082	BRASS	63824-3
STANDARD	H04	BRASS	△3 63824-2
STANDARD	082	BRASS	63824-1
REELING		MATERIAL	PART NO.

THIS DRAWING IS A CONTROLLED DOCUMENT.		DWN	20FEB01	TE Connectivity	
		CHK	20FEB01		
		MS FEHER			
		APVD	20FEB01		
DIMENSIONS:		TOLERANCES UNLESS OTHERWISE SPECIFIED:		NAME	
mm [INCHES]		0 PLC ±-		TAB, FASTON, P.C.BOARD	
		1 PLC ±-		6.35 [.250]	
		2 PLC ±-		-	
		3 PLC ± 0.25 [.010]		APPLICATION SPEC	
		4 PLC ±-		114-2115	
		ANGLES ±-		SIZE	
MATERIAL		FINISH		CAGE CODE	
SEE TABLE		△		A3 00779	
				DRAWING NO	
				C=63824	
				RESTRICTED TO	
				-	
				CUSTOMER DRAWING	
				SCALE	
				8:1	
				SHEET	
				1 of 1	
				REV	
				P2	