

5275

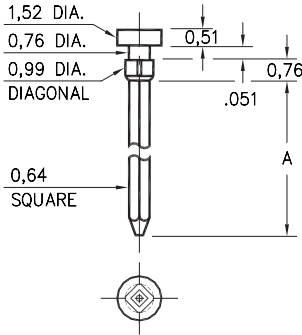

Basic Part Number	# of Wraps	Wrapost Length A
5275-1	1	9,40
5275-2	2	11,94
5275-3	3	15,49

5275-X-05-XX-00-00-01-0
Square press-fit in 0,89 plated thru hole

1010 ⇒ 1012/1020 ⇒ 1022

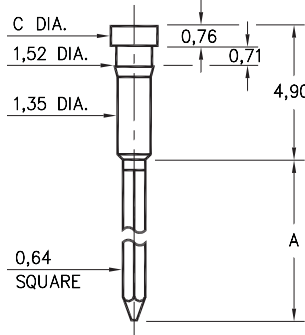

Basic Part Number	# of Wraps	Wrapost Length A	Head Dia. C
1012-1	1	6,60	1,83
1011-2	2	9,14	
1010-3	3	12,7	
1022-1	1	6,60	1,57
1021-2	2	9,14	
1020-3	3	12,7	

10XX-X-05-XX-00-00-01-0
Press-fit in 1,45 mounting hole

1215

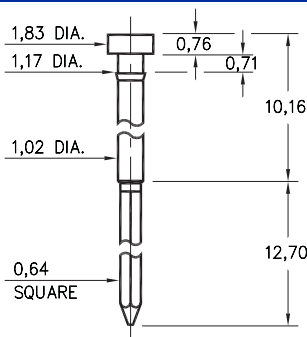

1215-3-05-XX-00-00-01-0
Press-fit in 1,09 mounting hole

1124

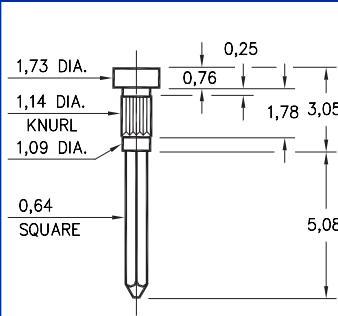

1124-0-05-XX-00-00-01-0
Press-fit in 1,09 mounting hole

1210

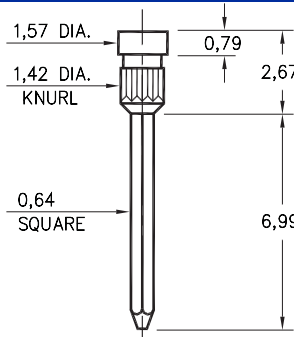

1210-0-05-XX-00-00-01-0
Press-fit in 1,35 mounting hole

1222

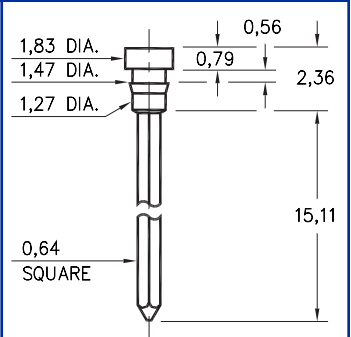

1222-0-05-XX-00-00-01-0
Press-fit in 1,40 mounting hole

1221

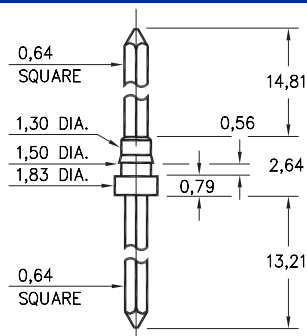

1221-0-05-XX-00-00-01-0
Press-fit in 1,42 mounting hole

1110

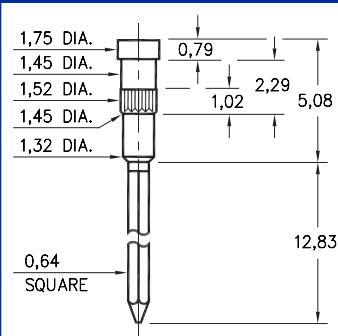

1110-3-05-XX-00-00-01-0
Press-fit in 1,45 mounting hole

1094

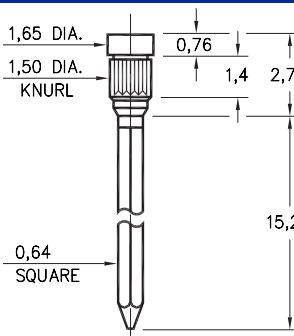

1094-0-05-XX-00-00-01-0
Press-fit in 1,42 mounting hole

SPECIFICATIONS

PIN MATERIAL:
Brass Alloy 360, 1/2 Hard

DIMENSION IN INCHES
TOLERANCES ON:
LENGTHS: ±0,13
DIAMETERS: ±0,05
ANGLES: ± 2°

ORDER CODE: XXXX - X - 05 - XX - 00 - 00 - 01 - 0

BASIC PART #

SPECIFY PIN FINISH:

- 01 5,08µm TIN/LEAD OVER NICKEL
- ◇ 80 5,08µm TIN OVER NICKEL (RoHS)
- ◇ 15 0,25µm GOLD OVER NICKEL (RoHS)
- ◇ 21 0,51µm GOLD OVER NICKEL (RoHS)

