

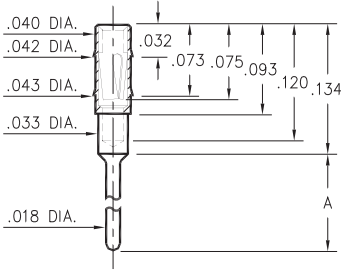

PIN RECEPTACLES
 for .015" - .020" diameter pins (#11 contact)
 and .015" - .022" diameter pins (#05 & #21 contacts)
 (see specific contact range on page 217)



0489



Basic Part Number	Length A
0489-0	.102
0489-1	.199
0489-2	.299

0489-X-15-XX-11-XX-04-0
 Press-fit in .041 mounting hole.

0463

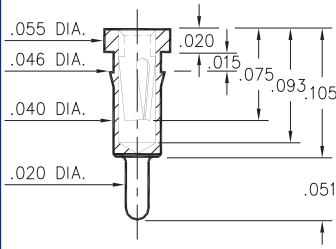

0463-0-15-XX-21-XX-04-0
 Press-fit in .043 mounting hole.
 shell is Phos. Br. Alloy 544 (B2)

0466

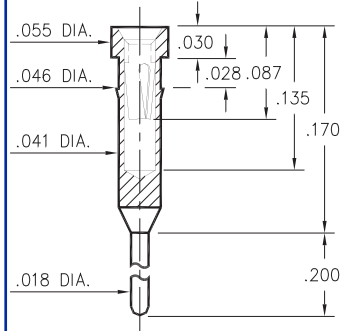

0466-0-15-XX-21-XX-04-0
 Press-fit in .043 mounting hole.
 shell is Phos. Br. Alloy 544 (B2)

7491

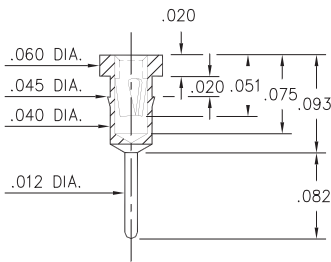

7491-0-15-XX-X1-XX-04-0
 Press-fit in .042 mounting hole

0462

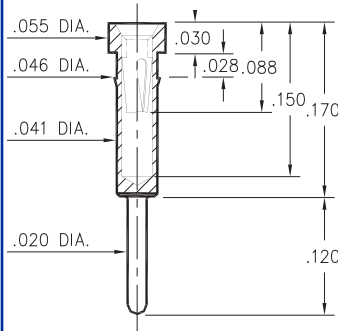

0462-0-15-XX-X1-XX-04-0
 Press-fit in .043 mounting hole

0560

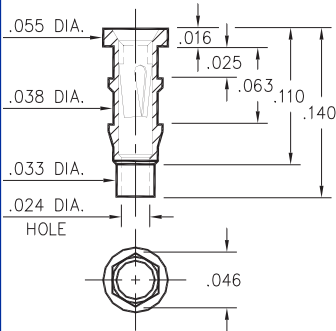

0560-0-15-XX-11-XX-10-0
 Hex press-fit in .043 plated thru hole

5552

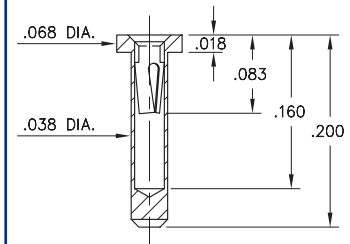

5552-0-15-XX-05-XX-10-0
 Solder mount in .040 min. mounting hole

4890

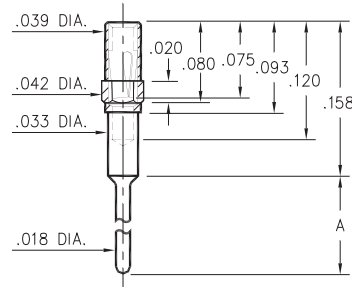

Basic Part Number	Length A
4890-0	.102
4890-1	.199
4890-2	.299

4890-X-15-XX-11-XX-04-0
 Octagonal press-fit in .041 mounting hole.

SPECIFICATIONS

SHELL MATERIAL:
 Brass Alloy 360, 1/2 Hard

CONTACT MATERIAL:
 Beryllium Copper Alloy 172, HT

DIMENSION IN INCHES
TOLERANCES ON:
 LENGTHS: ±.005
 DIAMETERS: ±.002
 ANGLES: ± 2°

ORDER CODE: XXXX - X - 1X - XX - XX - XX - XX - 0

BASIC PART #

SPECIFY SHELL FINISH:
 01 200µ" TIN/LEAD OVER NICKEL
 ◇ 80 200µ" TIN OVER NICKEL (RoHS)
 ◇ 15 10µ" GOLD OVER NICKEL (RoHS)

SPECIFY CONTACT FINISH:
 02 100µ" TIN/LEAD OVER NICKEL
 ◇ 84 100µ" TIN OVER NICKEL (RoHS)
 ◇ 27 30µ" GOLD OVER NICKEL (RoHS)



SELECT CONTACT

#05, #11 or #21 CONTACT (DATA ON PAGE 217)