

# Customer Information Sheet

DRAWING No.: H3490-XX

SHEET 2 OF 2

IF IN DOUBT - ASK

©

NOT TO SCALE

THIRD ANGLE PROJECTION

ALL DIMENSIONS IN mm

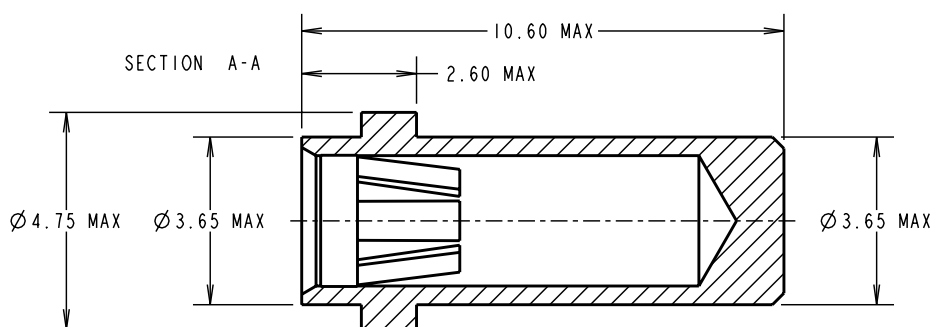

**SPECIFICATION:**

**MATERIALS:**

SHELL = BRASS CW614N TO BS EN 12164: 1998

CLIP = BERYLLIUM COPPER CI7200 HM

**FINISH:**

01 = 0.10-0.15µ GOLD CLIP, 3.5-5.0µ 100% TIN SHELL

05 = 0.10-0.15µ GOLD CLIP, 0.05-0.10µ GOLD SHELL

46 = 1.0-1.5µ 100% TIN CLIP, 3.5-5.0µ 100% TIN SHELL

**ELECTRICAL:**

CURRENT RATING = 20A MAX

CONTACT RESISTANCE = 25 MILLIOHMS MAX

**MECHANICAL:**

DURABILITY = 01 - 500 CYCLES

05 - 500 CYCLES

46 - 50 CYCLES

INSERTION FORCE (Ø2.00mm GAUGE) = 6N MAX, 3N MIN

WITHDRAWAL FORCE (Ø2.00mm GAUGE) = 3N MAX, 1N MIN

MATING PIN SIZE = Ø2.3-2.0mm

CONTACT DEPTH = 4.1mm MAX

PIN LENGTH = 8.50mm MAX

**ENVIRONMENTAL:**

TEMPERATURE RANGE = -55°C TO +125°C

FOR COMPLETE MECHANICAL AND ELECTRICAL SPECIFICATION

SEE COMPONENT SPECIFICATION C031XX (LATEST ISSUE).

**NOTES:**

1. RECOMMENDED MOUNTING HOLE = Ø3.77-3.67mm

ORDER CODE:

**H3490-XX**

FINISH:

01 = GOLD CLIP, TIN SHELL  
05 = GOLD CLIP, GOLD SHELL  
46 = 100% TIN CLIP, TIN SHELL

CP	5	05.02.10	10669
NAME	ISS.	DATE	C/NOTE
APPROVED: C.PENROSE			
CHECKED: R.ADDE			
DRAWN: A.LIOTTA			
CUSTOMER REF.:			
ASSEMBLY DRG:			

**HARWIN**

HARWIN USA  
TEL: 603 893 5376  
FAX: 603 893 5396  
mis@harwin.com

HARWIN Europe (UK)  
TEL: 023 9231 4545  
FAX: 023 9231 4590  
mis@harwin.co.uk

HARWIN Asia  
TEL: +65 6 779 4909  
FAX: +65 6 779 3868  
mis@harwin.com.sg

THIS DRAWING AND ANY INFORMATION OR DESCRIPTIVE MATTER SET OUT HEREON ARE CONFIDENTIAL AND COPYRIGHT PROPERTY OF THE HARWIN GROUP AND MUST NOT BE DISCLOSED, LOANED, COPIED OR USED FOR MANUFACTURING, TENDERING OR FOR ANY OTHER PURPOSE WITHOUT THEIR WRITTEN PERMISSION.

**TOLERANCES**  
X. = ±1mm  
X.X = ±0.25mm  
X.XX = ±0.10mm  
X.XXX = ±0.01mm  
ANGLES = ±5°  
UNLESS STATED

**MATERIAL:**  
SEE ABOVE  
**FINISH:** SEE ABOVE  
**S/AREA:** mm<sup>2</sup>

**TITLE:**  
Ø2.00mm SOCKET ASSEMBLY  
**DRAWING NUMBER:**  
**H3490-XX**

SHT  
2 OF 2