

Customer Information Sheet

DRAWING No.: H3165-XX

SHEET 2 OF 2

IF IN DOUBT - ASK

(C)

NOT TO SCALE

THIRD ANGLE PROJECTION

ALL DIMENSIONS IN mm

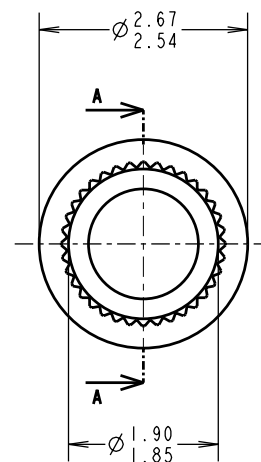
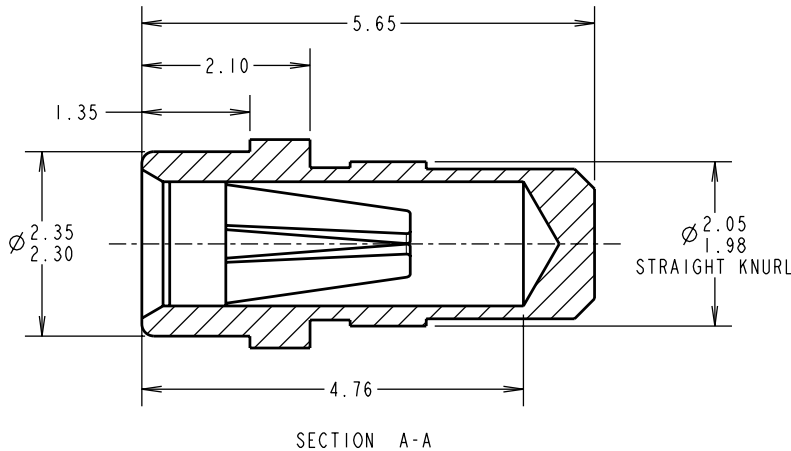

SPECIFICATION:

MATERIAL:
 CONTACT SHELL = BRASS
 CONTACT CLIP = BERYLLIUM COPPER

FINISH:
 01 = 4μ TIN SHELL, 0.15μ GOLD CLIP
 05 = 0.1μ GOLD SHELL, 0.15μ GOLD CLIP
 46 = 4μ 100% TIN SHELL, 3μ 100% TIN CLIP

ELECTRICAL:
 CURRENT RATING AT 25°C = 10A MAX
 CURRENT RATING AT 85°C = 7.5A MAX
 CONTACT RESISTANCE = 25 MILLIOHMS MAX

MECHANICAL:
 INSERTION FORCE (∅1mm GAUGE) = 9N MAX, 3N MIN
 WITHDRAWAL FORCE (∅1mm GAUGE) = 3N MAX, 1N MIN

DURABILITY:
 01, 05 = 1000 OPERATIONS
 46 = 100 OPERATIONS

ENVIRONMENTAL:
 OPERATING TEMPERATURE = -55°C TO +125°C

NOTES:

- FOR COMPLETE SPECIFICATION, SEE COMPONENT SPECIFICATION C009XX (LATEST ISSUE).
- MAXIMUM CONTACT DEPTH = 3.55mm.
- RECOMMENDED MOUNTING HOLE SIZE = ∅1.96-1.91mm.
- RECOMMENDED PIN SIZE = ∅1.05-0.90mm.
- MAXIMUM PIN LENGTH = 4.85mm.

ORDER CODE:

H3165-XX

FINISH:

- 01 = TIN SHELL, GOLD CLIP
- 05 = GOLD SHELL, GOLD CLIP
- 46 = 100% TIN SHELL & TIN CLIP

RA	17	11.02.09	10286
NAME	ISS.	DATE	C/NOTE
APPROVED:		R. ADDE	
CHECKED:			
DRAWN:		I. SANDY	
CUSTOMER REF.:			
ASSEMBLY DRG:			

HARWIN

HARWIN USA
 TEL: 603 893 5376
 FAX: 603 893 5396
 mis@harwin.com

HARWIN Europe (UK)
 TEL: 023 9231 4545
 FAX: 023 9231 4590
 mis@harwin.co.uk

HARWIN Asia
 TEL: +65 6 779 4909
 FAX: +65 6 779 3868
 mis@harwin.com.sg

THIS DRAWING AND ANY INFORMATION OR DESCRIPTIVE MATTER SET OUT HEREON ARE CONFIDENTIAL AND COPYRIGHT PROPERTY OF THE HARWIN GROUP AND MUST NOT BE DISCLOSED, LOANED, COPIED OR USED FOR MANUFACTURING, TENDERING OR FOR ANY OTHER PURPOSE WITHOUT THEIR WRITTEN PERMISSION.

TOLERANCES

X. = ±1mm
 X.X = ±0.25mm
 X.XX = ±0.10mm
 X.XXX = ±0.01mm

ANGLES = ±5°
 UNLESS STATED

MATERIAL:

SEE ABOVE

FINISH:

SEE ABOVE

S/AREA:

mm²

TITLE:

∅1.00mm SOCKET ASSEMBLY

DRAWING NUMBER:

H3165-XX

SHT
 2
 OF 2