

0388

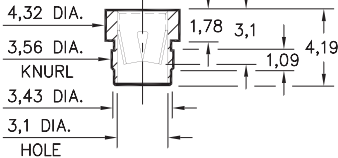

0388-0-15-XX-08-XX-10-0
Press-fit in 3,51 mounting hole

0390

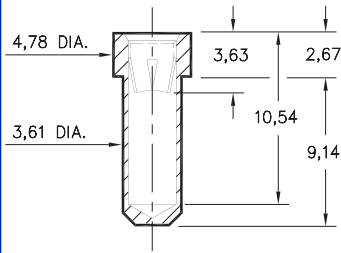

0390-0-15-XX-08-XX-10-0
Solder mount in 3,66 min. mounting hole

0389

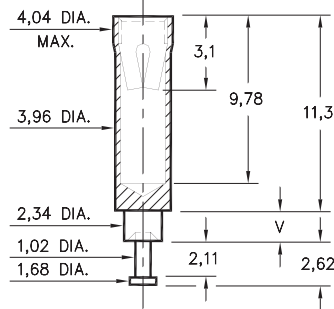

0389-X-15-XX-08-XX-10-0
Swage mount in 2,39 hole

Basic Part Number	Board Thickness	Length V
0389-2	1,57	2,39
0389-3	2,39	3,18
0389-4	3,18	3,96

8963

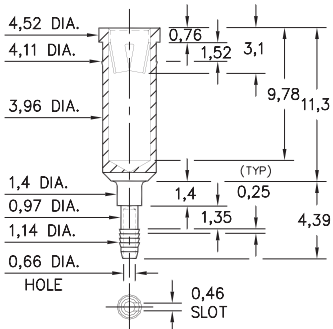

8963-0-31-XX-08-XX-04-0
Compliant press-fit in 1,02±0,08 plated hole. For 1,52→2,54 thick board.

SPECIFICATIONS

SHELL MATERIAL:
Brass Alloy 360, 1/2 Hard

CONTACT MATERIAL:
Beryllium Copper Alloy 172, HT

DIMENSION IN INCHES TOLERANCES ON:
LENGTHS: ±0,13
DIAMETERS: ±0,05
ANGLES: ± 2°

ORDER CODE: **XXXX - X - XX - XX - 08 - XX - 10 - 0**

BASIC PART #

- SPECIFY SHELL FINISH:**
- 01 5,08µm TIN/LEAD OVER NICKEL
 - ◇ 80 5,08µmTIN OVER NICKEL (RoHS)
 - ◇ 15 0,25µm GOLD OVER NICKEL (RoHS)

- SPECIFY CONTACT FINISH:**
- 01 5,08µm TIN/LEAD OVER NICKEL
 - ◇ 80 5,08µm TIN OVER NICKEL (RoHS)
 - ◇ 27 0,76µm GOLD OVER NICKEL (RoHS)



CONTACT

#08 CONTACT (DATA ON PAGE 226)