

0388

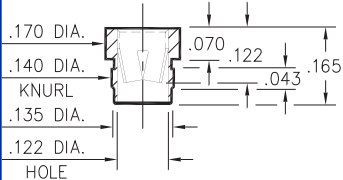

0388-0-15-XX-08-XX-10-0
Press-fit in .138 mounting hole

0390

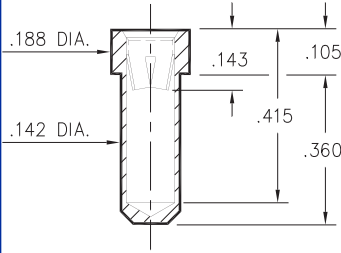

0390-0-15-XX-08-XX-10-0
Solder mount in .144 min. mounting hole

0389

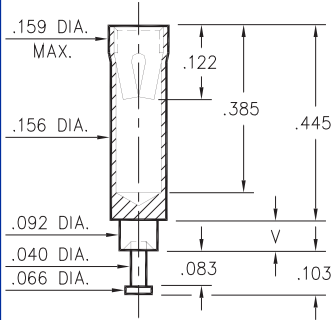

0389-X-15-XX-08-XX-10-0
Swage mount in .094 hole

Basic Part Number	Board Thickness	Length V
0389-2	.062	.094
0389-3	.094	.125
0389-4	.125	.156

8963

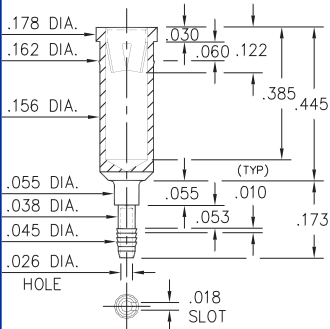

8963-0-31-XX-08-XX-04-0
Compliant press-fit in .040±.003 plated hole. For .060→.100 thick board.

SPECIFICATIONS

SHELL MATERIAL:
Brass Alloy 360, 1/2 Hard

CONTACT MATERIAL:
Beryllium Copper Alloy 172, HT

DIMENSION IN INCHES
TOLERANCES ON:
LENGTHS: ±.005
DIAMETERS: ±.002
ANGLES: ± 2°

ORDER CODE: **XXXX - X - XX - XX - 08 - XX - XX - 0**

BASIC PART #

SPECIFY SHELL FINISH:
01 200μ" TIN/LEAD OVER NICKEL
◇ 80 200μ" TIN OVER NICKEL (RoHS)
◇ 15 10μ" GOLD OVER NICKEL (RoHS)

SPECIFY CONTACT FINISH:
01 200μ" TIN/LEAD OVER NICKEL
◇ 80 200μ" TIN OVER NICKEL (RoHS)
◇ 27 30μ" GOLD OVER NICKEL (RoHS)



CONTACT

#08 CONTACT (DATA ON PAGE 226)