

0331/9353

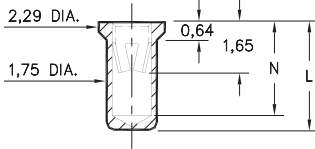

Basic Part Number	Length L	Depth N
0331-0	3,81	3,23
9353-0	4,32	3,73

X3XX-0-15-XX-18-XX-10-0

Solder mount in 1,80 min. mounting hole
Also available on 24mm wide carrier tape: 1,000 parts per 330mm reel.
Order as: X3XX-0-57-XX-18-XX-10-0

7405

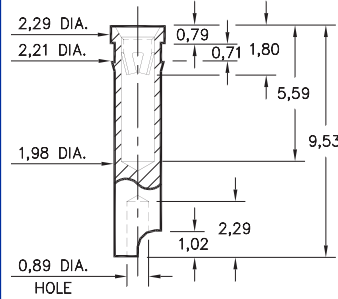

7405-0-18-XX-18-XX-10-0
Press-fit in 2,13 mounting hole

3450

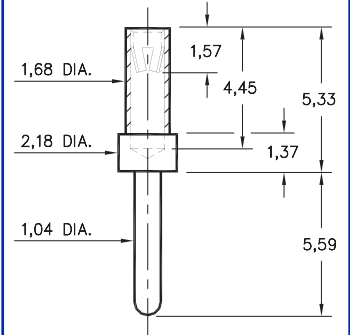

3450-0-15-XX-18-XX-04-0
Solder mount in 1,09 min. mounting hole

9354/7406

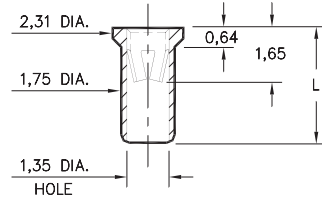

Basic Part Number	Length L
7406-0	3,05
9354-0	4,32

XXXX-0-15-XX-18-XX-10-0

Solder mount in 1,80 min. mounting hole

0319

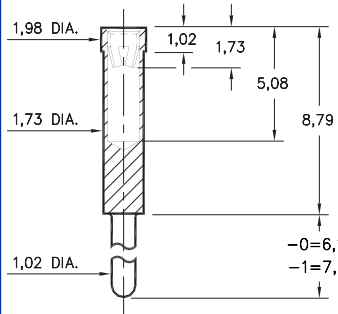

0319-X-15-XX-18-XX-04-0
Solder mount in 1,07 min. mounting hole

1313

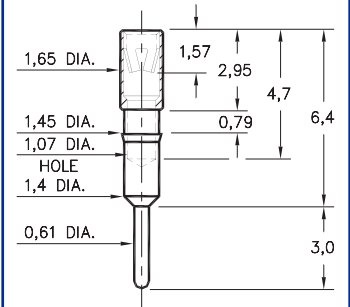

1313-0-15-XX-18-XX-04-0
Press-fit in 1,42 mounting hole

3520

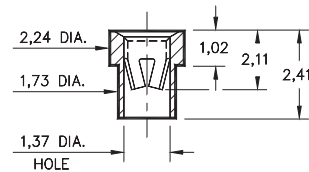

3520-0-15-XX-18-XX-10-0
Solder mount in 1,78 min. mounting hole

8331

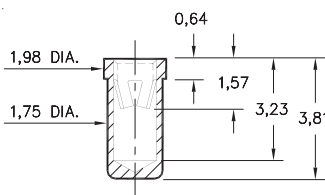

8331-0-15-XX-18-XX-10-0
Solder mount in 1,80 min. mounting hole
Also available on 24mm wide carrier tape: 1,000 parts per 330mm reel.
Order as: 8331-0-57-XX-18-XX-10-0

6628

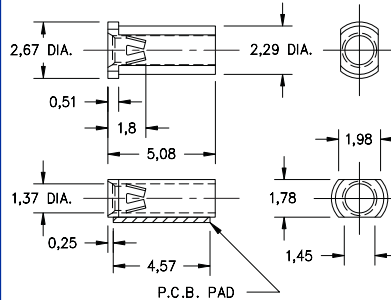

6628-0-18-XX-18-XX-10-0
Surface mount
Also available on 12mm wide carrier tape: 3,700 parts per 330mm reel.
Order as: 6628-0-58-XX-18-XX-10-0



P.C.B. Layout

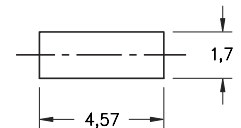

SPECIFICATIONS

SHELL MATERIAL:
Brass Alloy 360, 1/2 Hard

CONTACT MATERIAL:
Beryllium Copper Alloy 172, HT

DIMENSION IN INCHES
TOLERANCES ON:
LENGTHS: $\pm 0,13$
DIAMETERS: $\pm 0,05$
ANGLES: $\pm 2^\circ$

ORDER CODE: XXXX - X - 1X - XX - 18 - XX - XX - 0

BASIC PART #

SPECIFY SHELL FINISH:
01 5,08 μ m TIN/LEAD OVER NICKEL
◇ 80 5,08 μ m TIN OVER NICKEL (RoHS)
◇ 15 0,25 μ m GOLD OVER NICKEL (RoHS)

SPECIFY CONTACT FINISH:
01 5,08 μ m TIN/LEAD OVER NICKEL
◇ 80 5,08 μ m TIN OVER NICKEL (RoHS)
◇ 27 0,76 μ m GOLD OVER NICKEL (RoHS)



CONTACT

#18 CONTACT (DATA ON PAGE 222)