

0327/0351/0373

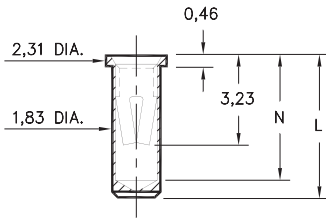

Basic Part Number	Length L	Depth N
0327-0	5,23	4,57
0351-0	5,74	5,08
0373-0	6,86	6,12

T&R Packaging

Basic Part Number	Tape Width	Parts per 330mm Reel
0327-0	14mm	1,400
0351-0	24mm	1,100

03XX-0-15-XX-34-XX-10-0

Solder mount in 1,91 min. mounting hole
Also available on 12mm or 24mm wide carrier tape: See chart for Details.
Order as: 03XX-0-57-XX-34-XX-10-0

0328

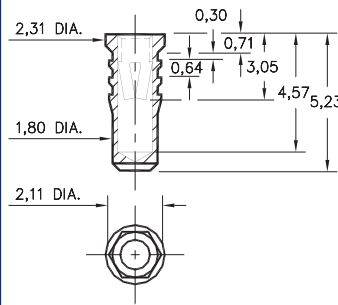

0328-0-15-XX-34-XX-10-0

Hex press-fit in 2,01 plated thru hole

0334

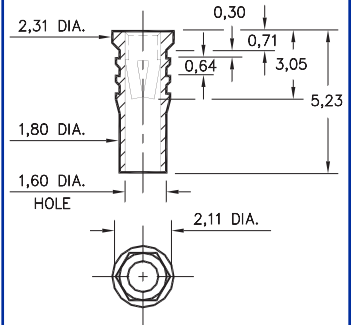

0334-0-15-XX-34-XX-10-0

Hex press-fit in 2,01 plated thru hole

0312

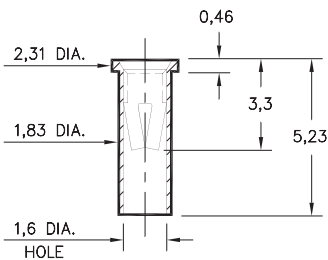

0312-0-15-XX-34-XX-10-0

Solder mount in 1,91 min. mounting hole
Also available on 12mm wide carrier tape: 1,400 parts per 330mm reel.
Order as: 0312-0-57-XX-34-XX-10-0

0333

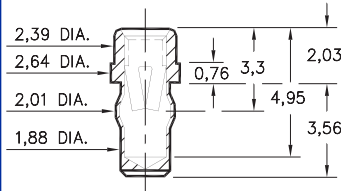

0333-0-42-XX-34-XX-10-0

Press-fit in 1,93 mounting hole

0357

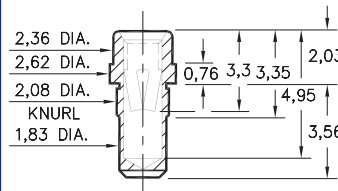

0357-0-15-XX-34-XX-10-0

Press-fit in 1,98 mounting hole

0317

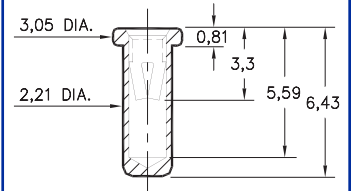

0317-0-15-XX-34-XX-10-0

Solder mount in 2,31 min. mounting hole

0340

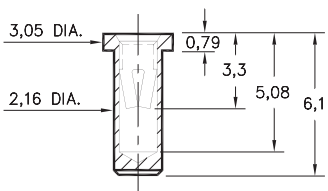

0340-0-15-XX-34-XX-10-0

Solder mount in 2,21 min. mounting hole

0345

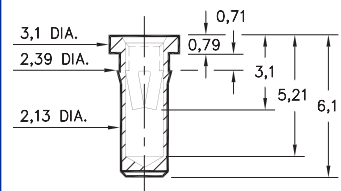

0345-0-15-XX-34-XX-10-0

Press-fit in 2,26 mounting hole

0316

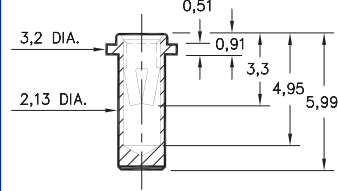

0316-0-15-XX-34-XX-10-0

Solder mount in 2,21 min. mounting hole

0314

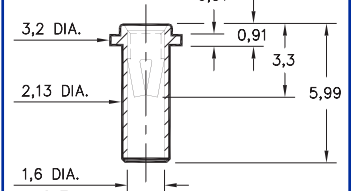

0314-0-15-XX-34-XX-10-0

Solder mount in 2,21 min. mounting hole

SPECIFICATIONS

SHELL MATERIAL:
Brass Alloy 360, 1/2 Hard

CONTACT MATERIAL:
Beryllium Copper Alloy 172, HT

DIMENSION IN INCHES
TOLERANCES ON:
LENGTHS: ±0,13
DIAMETERS: ±0,05
ANGLES: ± 2°

ORDER CODE: XXXX - X - XX - XX - 34 - XX - 10 - 0

BASIC PART #

SPECIFY SHELL FINISH:
01 5,08µm TIN/LEAD OVER NICKEL
◇ 80 5,08µm TIN OVER NICKEL (RoHS)
◇ 15 0,25µm GOLD OVER NICKEL (RoHS)

SPECIFY CONTACT FINISH:
01 5,08µm TIN/LEAD OVER NICKEL
◇ 80 5,08µm TIN OVER NICKEL (RoHS)
◇ 27 0,76µm GOLD OVER NICKEL (RoHS)



CONTACT

#34 CONTACT (DATA ON PAGE 222)