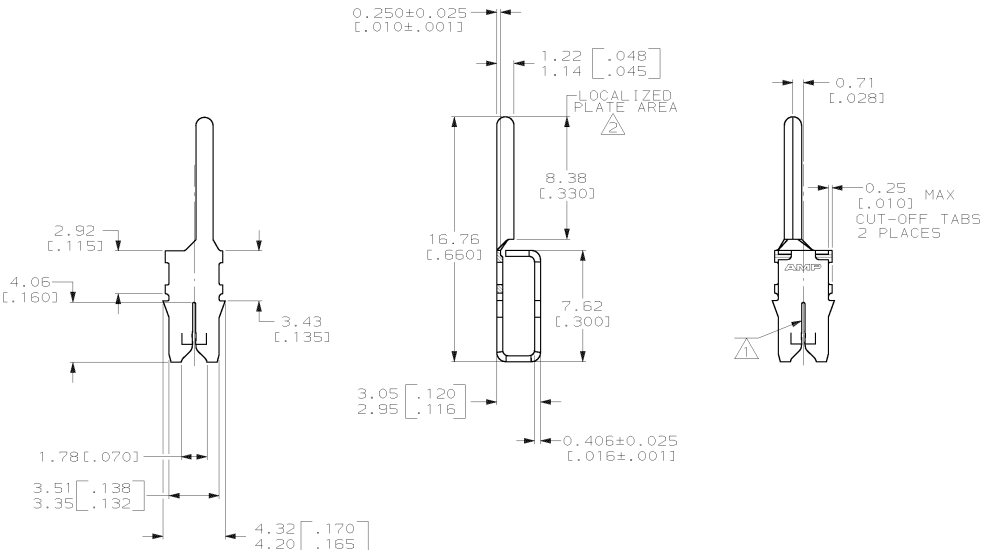

THIS DRAWING IS UNPUBLISHED. RELEASED FOR PUBLICATION .19
 © COPYRIGHT 19 BY AMP INCORPORATED. ALL INTERNATIONAL RIGHTS RESERVED.

LOC	DIST	P	F	ZONE	LTR	REVISIONS	DATE	APPRO
AF	50				A	REL PER 0L10-0430-97	11/4/97	JR/NN

- △ SLOT TERMINATES EITHER SINGLE OR DOUBLE MAGNET WIRES OF THE SAME TYPE AND SIZE, COPPER RANGE IS 0.36-0.57mm [#27-#23 AWG] 0.00508 [.000200] MIN TIN PLATE IN LOCALIZED PLATE AREA, REMAINDER TO BE 0.002032 [.000080] MIN TIN.

IDENTIFICATION NUMBER 10 FOR MAGNET WIRE RANGE

THIS DRAWING IS A CONTROLLED DOCUMENT FOR AMP INCORPORATED. IT IS SUBJECT TO CHANGE AND THE CONTROLLING ENGINEERING ORGANIZATION SHOULD BE CONTACTED FOR THE LATEST REVISION.

		63880-1	
		PART NO	
DO NOT SCALE PRINT. UNLESS SPECIFIED DIMENSIONS IN mm (INCHES) TOLERANCES ON: 2 PLC DEC ± 0.15 (.006) 3 PLC DEC ± - ANGLES ± -		 AMP Incorporated Harrisburg, PA 17105-3608	
MATERIAL 4M PRE-MILLED BRASS		NAME PIN, LOOSE PIECE, 1.22 [.048] DIA, LEFT HAND, MAG-MATE™	
FINISH △		DRAWING NO C-63880	
APPLICATION SPEC 114-2046		CAGE CODE 00779	
WEIGHT -		SCALE 5:1	
		SHEET 1 OF 1	

CUSTOMER DRAWING