

THE DRAWING IS UNPUBLISHED. RELEASED FOR PUBLICATION. BY TYCO ELECTRONICS CORPORATION. ALL RIGHTS RESERVED.

LOC	QST	REV	DESCRIPTION	DATE	BY	APP
AF	50	B	REVISED PER ECR-06-010412	09NOV06	HMR	KR

- 1 CONTINUOUS STRIP ON REELS WITH TERMINALS LOCATED ON 8.38±0.08 [.330±.003] CENTERS.
- 2 SLOT TERMINATES EITHER A SINGLE OR DOUBLE MAGNET WIRES OF THE SAME TYPE AND SIZE, COPPER RANGE: 0.36-0.57mm [#27-#23] AWG.
- 3 AFTER INSERTION INTO PLASTIC HOLDER TAB PORTION MUST BE BENT OVER 45° TO 90° OR POTTED-IN TO PREVENT PULL-OUT WHEN MATING RECEPTACLE IS DISCONNECTED.
- 4 CAVITY SPECIFICATION TO BE MODIFIED TO ACCEPT WIDER TAB TRANSITION.

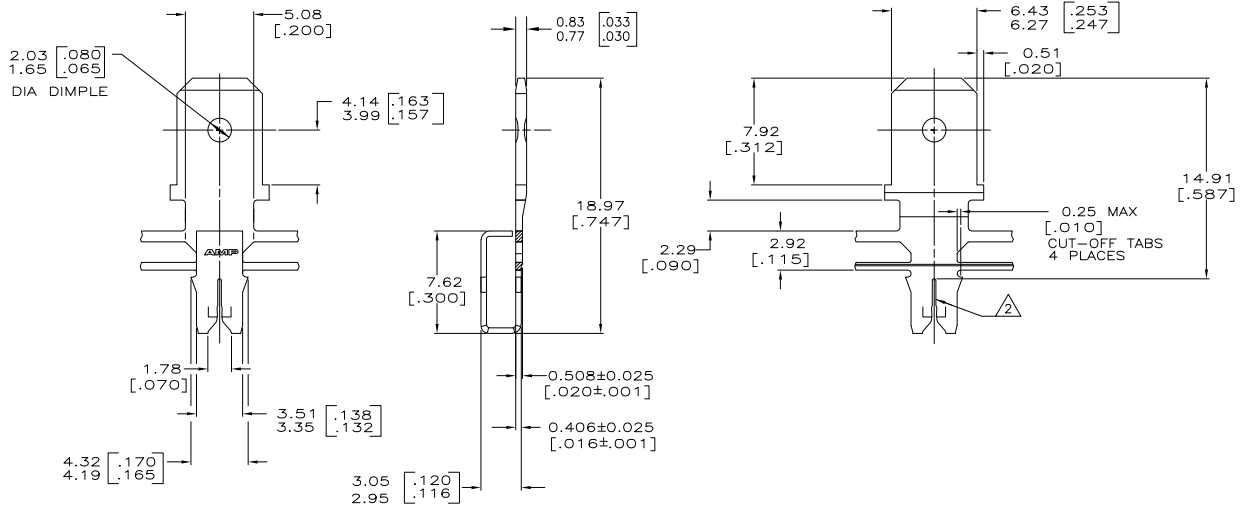

63920-1  
PART NUMBER

THIS DRAWING IS A CONTROLLED DOCUMENT.		DRN MICHAEL S. FEHER 10A43R	TYCO Electronics	Tyco Electronics Corporation Harrisburg, PA 17105-3608
DIMENSIONS: mm [INCHES]		DRG RICHARD GRZYBOWSKI 13A23R	APR GARY PORTA 12A43R	TAB, 6.35[.250] FASTON, MAG-MATE™
TOLERANCES UNLESS OTHERWISE SPECIFIED:		PRODUCED SPEC 108-2012	APPLICATION SPEC 114-2046	RESTRICTED TO
MATERIAL: DBZ PFC-MILLED BRASS		FINISH 0.0020(32) (00008)	MIN TIN PER MIL-1-10727	WEIGHT -
CUSTOMER DRAWING		SIZE A2	CAGE CODE 00779	DRAWING NO 63920
SCALE 5:1		SHEET 1 of 1		REV B

AMP 1471-B REV 31MM2000

63920

A