

| REV. NO. | | REVISIONS | | DATE | BY | APP. |
|----------|----|-----------|----------------------|---------|----|------|
| AF | 50 | TW | REWORK FOR | | | |
| E | | | REV PER 063A-0193-02 | 15MAR02 | JR | KAR |

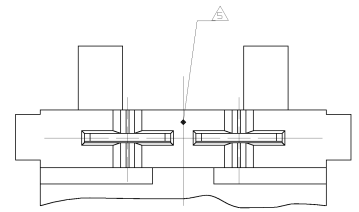

- 1 CONTINUOUS STRIP ON REELS WITH TERMINALS LOCATED ON 11.18±0.08 [1.440±.003] CENTERS
- △ SLOTS ACCEPTS 0.18 - 0.23mm [1*33-#31] AWG COPPER MAGNET WIRE. TWO WIRES OF THE SAME SIZE MAX PER SLOT.
- △ SLOT ACCEPTS A SINGLE 0.6mm [1*22.5] AWG SOLID BARE COPPER WIRE
- △ IDENTIFICATION NUMBER 4-22; 4 FOR THE MAGNET WIRE SLOT SIZE AND 22 FOR THE LEADWIRE SLOT SIZE
- △ POINT OF MEASUREMENT, LOCATED APPROXIMATELY AS SHOWN

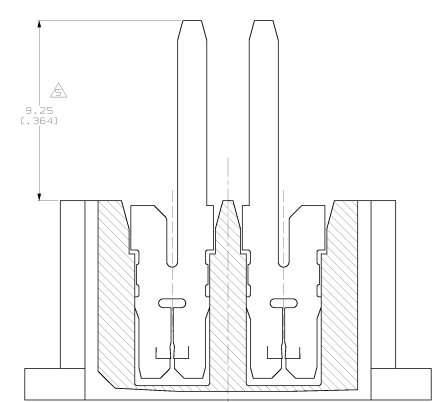
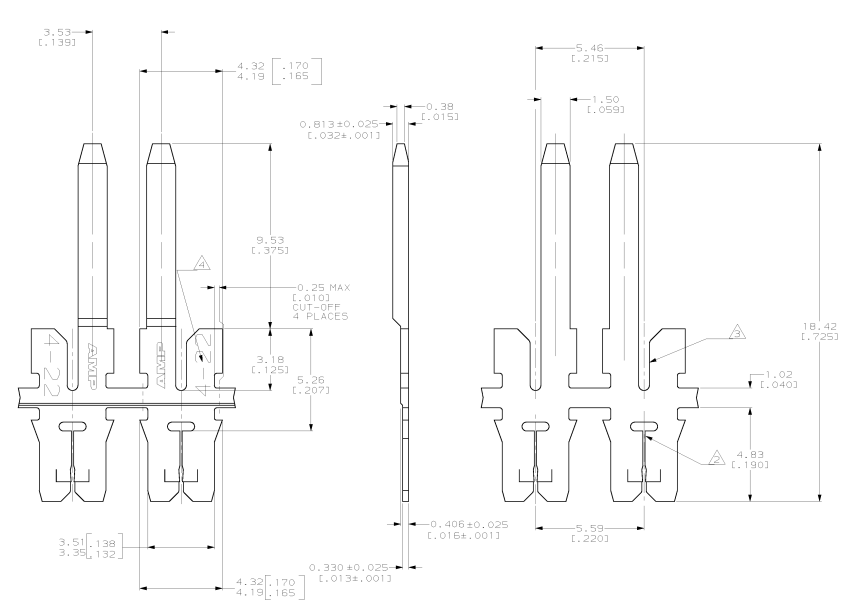

INSERTION SPECIFICATION

63903-1
 PART NUMBER

| | | | | | |
|--|--|------|-----------|-------|-------|
| THIS DRAWING IS A CONTROLLED DOCUMENT. | | DC | 027450061 | 0.000 | |
| DRAWN BY: S. S. FEUER | | DATE | 01/19/02 | SCALE | 1:1 |
| CHECKED BY: S. S. FEUER | | DATE | 01/19/02 | SCALE | 1:1 |
| APPROVED BY: S. S. FEUER | | DATE | 01/19/02 | SCALE | 1:1 |
| PART NAME: TERMINAL, POSTED, DUAL IDC, MAG-MATE™ Slim Line | | REV | 00778 | REV | 00778 |
| MATERIAL: PRE-MILLED BRASS | | REV | 00778 | REV | 00778 |
| DRAWING NO: 00778 | | REV | 00778 | REV | 00778 |