

THIS DRAWING IS UNPUBLISHED. RELEASED FOR PUBLICATION .19
 © COPYRIGHT 19 BY AMP INCORPORATED. ALL INTERNATIONAL RIGHTS RESERVED.

LOC		DIST		ZONE		LTR		REVISIONS		DATE	APPD
AF	50	P	F					DESCRIPTION	FFERRB	RG/EH	
								D	REV PER 0110-0043-98		

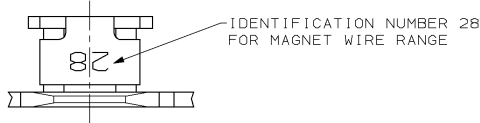

- CONTINUOUS STRIP ON REELS WITH TERMINALS LOCATED ON 5.59±0.08 [.220±.003] CENTERS. SLOT TERMINATES A SINGLE MAGNET WIRE ONLY. COPPER RANGE: 0.91-1.15mm [#19-#17] AWG. ALUMINUM RANGE: 1.02-1.22mm [#18-#16.5] AWG, WITH CAVITY ANVIL HEIGHT TO BE 2.29±0.13 [.090±.005] FOR ALUMINUM WIRE ONLY.
- AFTER INSERTION INTO PLASTIC HOLDER TAB PORTION MUST BE BENT OVER 45° TO 90° OR POTTED-IN TO PREVENT PULL-OUT WHEN MATING RECEPTACLE IS DISCONNECTED.
- VARNISH RESIST OVER 0.002032 [.000080] MIN TIN PER MIL-T-10727.

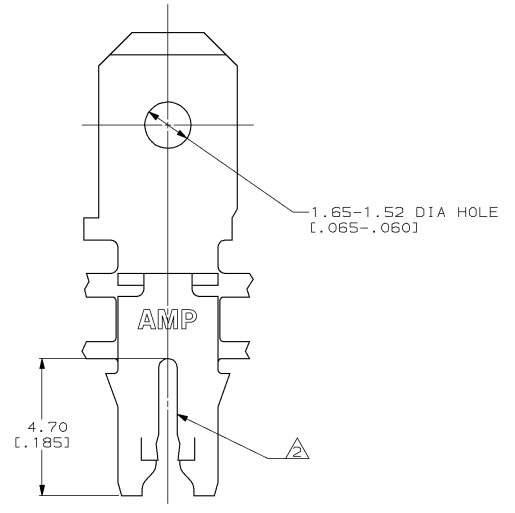
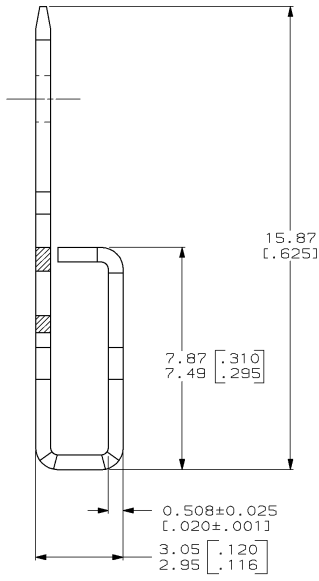
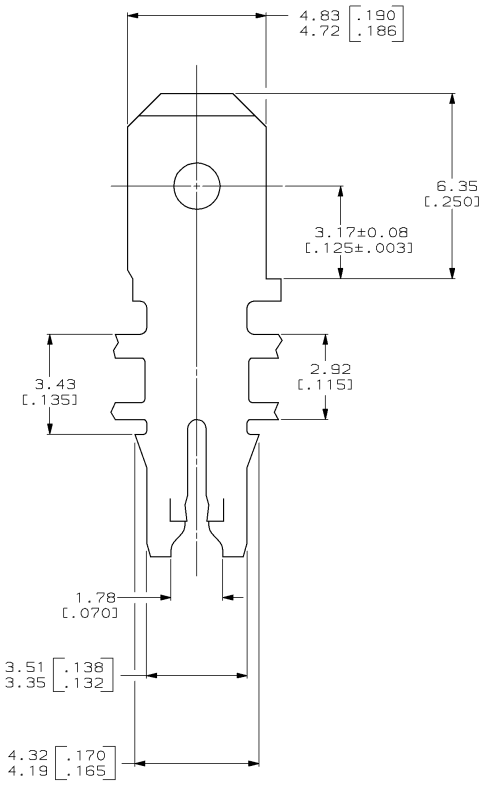

63665-1
PART NO

DO NOT SCALE PRINT. UNLESS SPECIFIED DIMENSIONS IN mm [INCHES] TOLERANCES ON: 2 PLC DEC ± 0.25 [.010] 3 PLC DEC ± ANGLES ± -		DR 9/4/92 MICHAEL S. FEHER	AMP Incorporated Harrisburg, PA 17105-3608	
MATERIAL 4M BRASS		CHK 9/7/92 JEFF R. RUTH		
FINISH A		APPD 9/15/92 NELSON E. NEFF	NAME TERMINAL, TAB, 4.75 [.187] FASTON, MAG-MATE	
APPLD 9/15/92 TERRY L. SHUTTER		PRODUCT SPEC 108-2012	SIZE C	CAGE CODE 00779
WEIGHT -		APPLICATION SPEC 114-2046 A	DRAWING NO C-63665	SHEET 1 OF 1
		SCALE 10:1	CUSTOMER DRAWING	

THIS DRAWING IS A CONTROLLED DOCUMENT FOR AMP INCORPORATED. IT IS SUBJECT TO CHANGE AND THE CONTROLLING ENGINEERING ORGANIZATION SHOULD BE CONTACTED FOR THE LATEST REVISION.

63665