

DRAWING MADE IN THIRD ANGLE PROJECTION

THIS DRAWING IS UNPUBLISHED. RELEASED FOR PUBLICATION, 19 .
 © COPYRIGHT 19 BY AMP INCORPORATED. ALL INTERNATIONAL RIGHTS RESERVED.

LOC	DIST	REVISIONS				DATE	APPD
P	F	ZONE	LTR	DESCRIPTION			
AF	50		L	REV PER 0L10-0072-96	29AUG96	RG/KR	

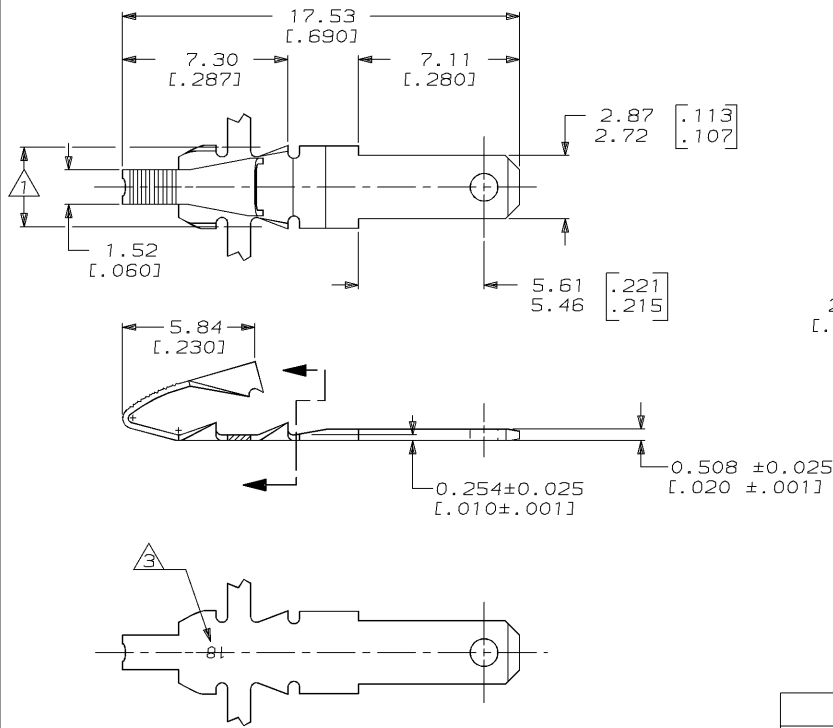

- ① 3.78 ± 0.13 [.149 ± .005] APPLICATOR CUT-OFF.
- ② CONTINUOUS STRIP ON REELS WITH TERMINALS LOCATED ON 6.10 [.240] CENTERS.
- ③ IDENTIFICATION NUMBER 18 FOR MAGNET WIRE RANGE.

METRIC

0.10-0.25mm [#38-#30] AWG	63161-1
MAGNET WIRE RANGE	PART NO

DO NOT SCALE PRINT. UNLESS SPECIFIED DIMENSIONS IN mm (INCHES) TOLERANCES ON: 2 PLC DEC ± 0.25 (.010) 3 PLC DEC ± - ANGLES ± -	DR 2/3/82 MICHAEL S. FEHER	AMP AMP INCORPORATED Harrisburg, Pa. 17105
	CHK 2/3/82 PHILLIP FORTNEY	
MATERIAL H02 PRE-MILLED BRASS	APPD 2/4/82 NELSON E. NEFF	NAME TAB, 2.79 [.110] FASTON™ MINI MAG-MATE™
FINISH 0.002032 [.000080] MIN TIN PER MIL-T-10727	APPD 2/4/82 TERRY L. SHUTTER	SIZE B
	PRODUCT SPEC 108-2016	CAGE CODE 00779
	APPLICATION SPEC 114-2047	DRAWING NO 63161
	WEIGHT -	SCALE 6:1
		SHEET 1 OF 1

CUSTOMER DRAWING