

4

3

2

1

THIS DRAWING IS UNPUBLISHED. RELEASED FOR PUBLICATION
 © COPYRIGHT - BY TYCO ELECTRONICS CORPORATION. ALL RIGHTS RESERVED.

LOC	DIST	REVISIONS			
P	LTR	DESCRIPTION	DATE	DWN	APVD
AF	50	D1	REL PER ECR 06-000469	13JAN06	JR KR

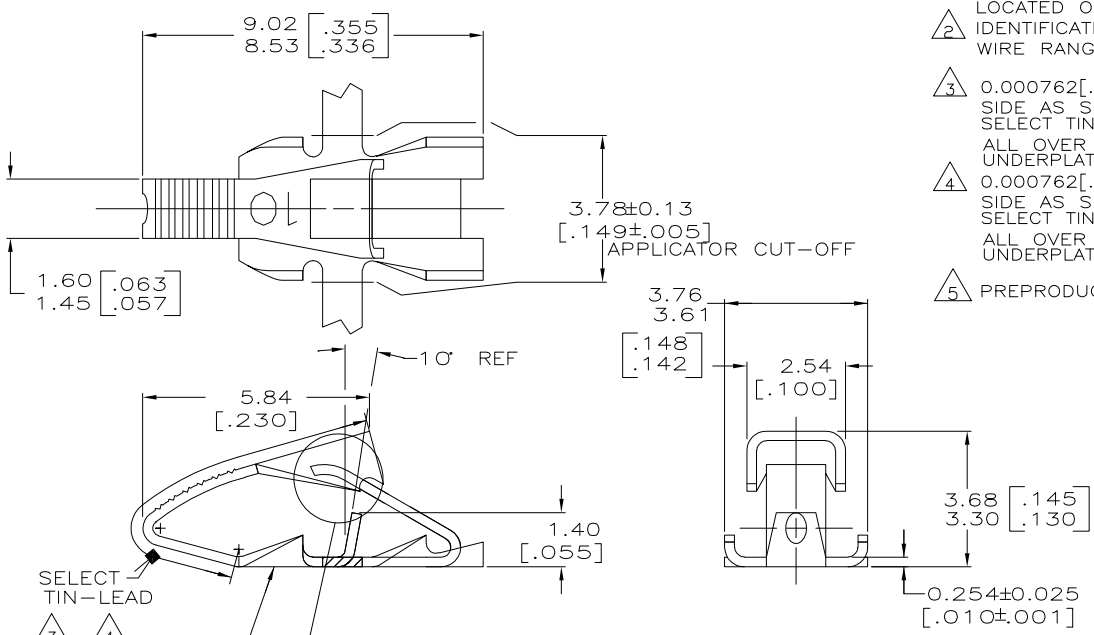

- 1 CONTINUOUS STRIP ON REELS WITH TERMINALS LOCATED ON 6.10±0.08 [.240±.003] CENTERS. IDENTIFICATION NUMBER 10 FOR MAGNET WIRE RANGE.
- 2
- 3 0.000762[.000030] MIN SELECT GOLD ON ONE SIDE AS SHOWN, 0.00127[.000050] MIN SELECT TIN-LEAD ON BOTH SIDES AS SHOWN ALL OVER 0.00127[.000050] MIN NICKEL UNDERPLATE
- 4 0.000762[.000030] MIN SELECT GOLD ON ONE SIDE AS SHOWN, 0.00127[.000050] MIN SELECT TIN ON BOTH SIDES AS SHOWN ALL OVER 0.00127[.000050] MIN NICKEL UNDERPLATE
- 5 PREPRODUCTION - FASR REQUIRED

0.05-0.13mm [#44-#36] AWG	4	5	63845-2
0.05-0.13mm [#44-#36] AWG	3		63845-1
COPPER MAGNET WIRE RANGE		FINISH	PART NO.

THIS DRAWING IS A CONTROLLED DOCUMENT.

DWN	R. GRZYBOWSKI	4/MAY/95	Tyco Electronics Corporation Harrisburg, Pa 17105-3608
CHK	M.S. FEHER	4/MAY/95	
APVD	TL SHUTTER	4/MAY/95	NAME
DIMENSIONS: MM [INCHES]			PRODUCT SPEC
TOLERANCES UNLESS OTHERWISE SPECIFIED:			APPLICATION SPEC
0 PLC	± -		108-2016
1 PLC	± -		114-2047
2 PLC	± 0.25 [.010]		WEIGHT
3 PLC	± -		
4 PLC	± -		
ANGLES	± -		
MATERIAL	H02 BRASS	FINISH	SEE TABLE
CUSTOMER DRAWING		SIZE	A3
		CAGE CODE	00779
		DRAWING NO	63845
		RESTRICTED TO	
		SCALE	10:1
		SHEET	1 OF 1
		REV	D1

AMP 1470-19 REV 31MAR2000