

THIS DRAWING IS UNPUBLISHED.
 RELEASED FOR PUBLICATION
 BY TYCO ELECTRONICS CORPORATION. ALL RIGHTS RESERVED.

LOC	QST	REVISIONS			
TR	LR	DESCRIPTION	DATE	DRN	APPD
B		REVISED PER ECR-06-010412	02NOV06	HMR	KR

IDENTIFICATION NUMBER 10 FOR
 MAGNET WIRE RANGE

1 CONTINUOUS STRIP ON REELS WITH TERMINALS
 LOCATED ON 8.38 ± 0.08 [.330 ± .003] CENTERS.
 2 SLOT ACCEPTS $0.36 - 0.58$ mm [#27-#23] AWG COPPER
 MAGNET WIRE. 2 WIRES MAX OF THE SAME SIZE AND
 SHAPE PER SLOT.

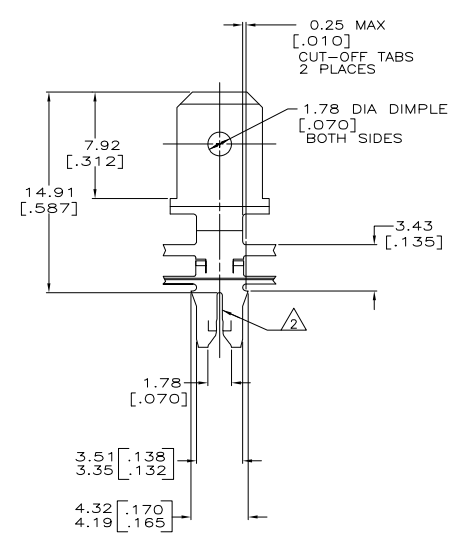
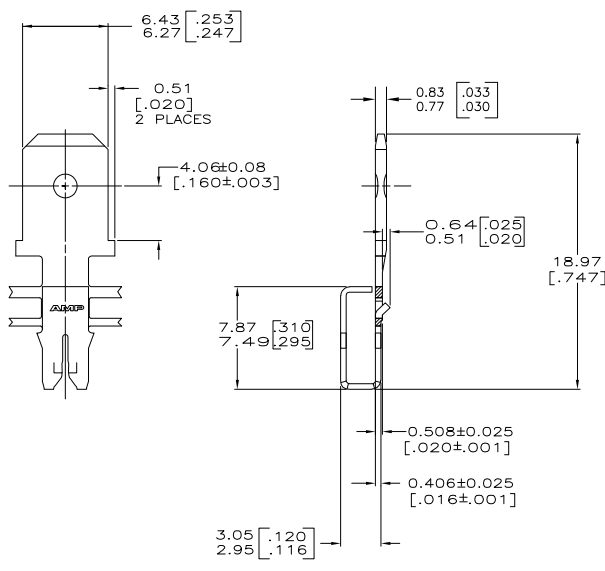

1217860-1
 PART NUMBER

THIS DRAWING IS A CONTROLLED DOCUMENT.		DRN MICHAEL S. FEUER	30JUL2002	Tyco Electronics Corporation Harrisburg, PA 17105-3608
DIMENSIONS: TO DIMENSIONS UNLESS OTHERWISE SPECIFIED:		DRN KURT A. RANDELEH	30JUL2002	
mm [INCHES]		DRN KURT A. RANDELEH	30JUL2002	1217860-1
		PRODUCT SPEC	108-2012	TERMINAL TAB, 6.35[.250] FASTON, 300 SERIES MAG-MATE™
		APPLICATION SPEC	114-2067	SIZE A2
MATERIAL	02Z PFC-MILLED BRASS	FINISH	0.0020(32) (000080)	WEIGHT
	MIN TN PLATE			CUSTOMER DRAWING
				SCALE 5:1
				SHEET 1 of 1
				REV B

AMP 1471-B REV 31MMR2000

1217860