

DRAWING MADE IN THIRD ANGLE PROJECTION

THIS DRAWING IS UNPUBLISHED. RELEASED FOR PUBLICATION, 19 .

© COPYRIGHT 19 BY AMP INCORPORATED. ALL INTERNATIONAL RIGHTS RESERVED.

LOC	DIST	REVISIONS				DATE	APPD
P	F	ZONE	LTR	DESCRIPTION			
AF	50		B	REVISE PER ECN 0G1A-0178-98	07AUG98	SU/KR	

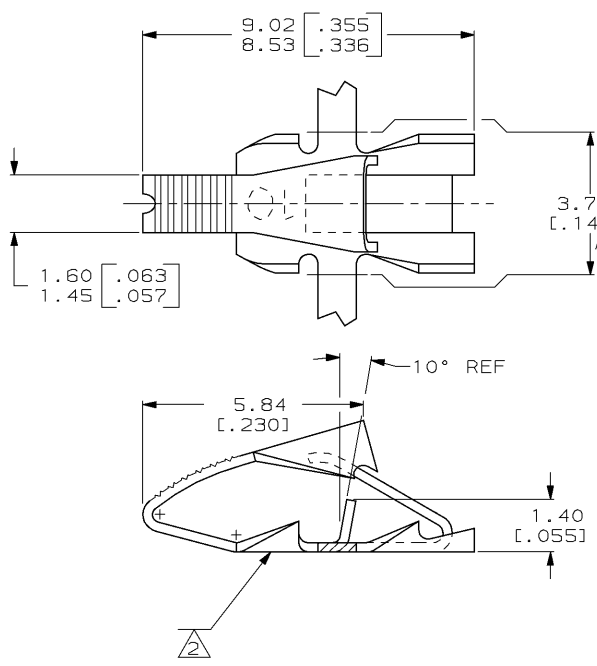

1 CONTINUOUS STRIP ON REELS WITH TERMINALS LOCATED ON 6.10±0.08 [.240±.003] CENTERS.

2 IDENTIFICATION NUMBER (10) FOR MAGNET WIRE RANGE.

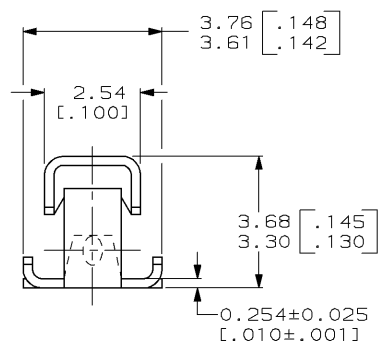

PROPOSED DESIGN  
NOT RELEASED FOR  
PRODUCTION

THIS DRAWING IS A CONTROLLED DOCUMENT FOR AMP INCORPORATED. IT IS SUBJECT TO CHANGE AND THE CONTROLLING ENGINEERING ORGANIZATION SHOULD BE CONTACTED FOR THE LATEST REVISION.

0.05-0.13mm [#44-#36] AWG		63795-1	
COPPER MAGNET WIRE RANGE		PART NUMBER	
DO NOT SCALE PRINT. UNLESS SPECIFIED DIMENSIONS IN mm (INCHES) TOLERANCES ON: 2 PLC DEC ± 0.25 (.010) 3 PLC DEC ± - ANGLES ± -		<b>AMP</b> AMP Incorporated Harrisburg, PA 17105-3608	
DR 15/JUN/84 MICHAEL S. FEHER CHK 15/JUN/84 JEFF R. RUTH APPD 15/JUN/84 ALEX HUNT III APPD 15/JUN/84 TERRY L. SHUTTER		NAME TERMINAL, POKE-IN, MINI MAG-MATE™	
MATERIAL H02 BRASS		SIZE B CAGE CODE 00779 DRAWING NO C=63795	
FINISH 0.002032 [.000080] MIN TIN PER MIL-T-10727		APPLICATION SPEC 114-2047 WEIGHT - SCALE 10:1 SHEET 1 OF 1	