

DRAWING MADE IN THIRD ANGLE PROJECTION

THIS DRAWING IS UNPUBLISHED. RELEASED FOR PUBLICATION, 19 .
 © COPYRIGHT 19 BY AMP INCORPORATED. ALL INTERNATIONAL RIGHTS RESERVED.

LOC	DIST	REVISIONS				
P	F	ZONE	LTR	DESCRIPTION	DATE	APPD
AF	50		M	REVISE PER ECN 0G1A-0178-98	06AUG98	SU/KR

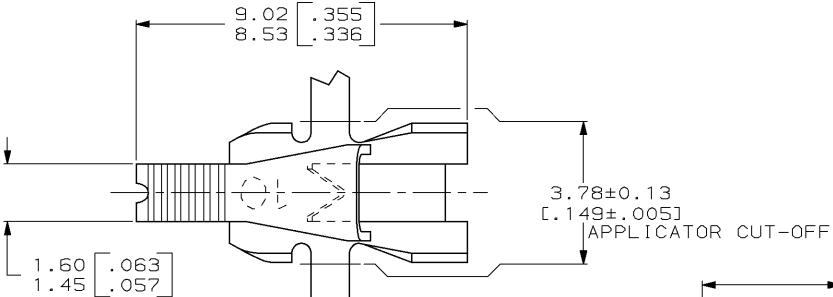

- 1 CONTINUOUS STRIP ON REELS WITH TERMINALS LOCATED ON 6.10 [0.240] CENTERS.
- ② IDENTIFICATION NUMBER (10) FOR MAGNET WIRE RANGE.
- ③ SOLID OR FUSED STRANDED LEAD WIRE 0.3-0.9mm² [#22-#18] AWG.

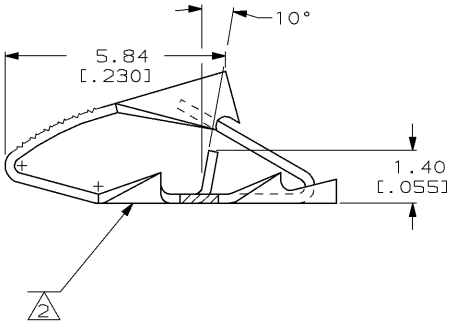
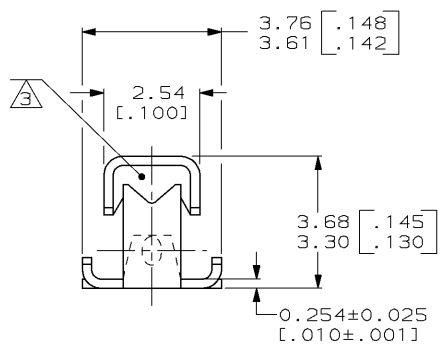

0.05-0.13mm [#44-#36] AWG	62780-1
COPPER MAGNET WIRE RANGE	PART NUMBER

DO NOT SCALE PRINT. UNLESS SPECIFIED DIMENSIONS IN mm [INCHES] TOLERANCES ON: 2 PLC DEC ± 3 PLC DEC ± 0.25 (.010) ANGLES ±	DR 9/27/88	AMP AMP INCORPORATED Harrisburg, Pa. 17105	NAME TERMINAL, POKE-IN, MINI MAG-MATE™	
	CHK 10/12/88			
	APPD 10/12/88			
	APPD 10/12/88			
MATERIAL	PRODUCT SPEC	SIZE	CAGE CODE	DRAWING NO
H02 HARD BRASS	-	B	00779	62780
FINISH	APPLICATION SPEC	SCALE	SHEET	
0.002032 [0.00080] MIN TIN PER MIL-T-10727	114-2047	10:1	1 OF 1	
WEIGHT	-			



AMP 1470-15 REV 6-88
 06-AUG-98 14:50:38 amp13029 /home/amp13029/ndmod

CUSTOMER DRAWING