

4

3

2

1

THIS DRAWING IS UNPUBLISHED. RELEASED FOR PUBLICATION
 © COPYRIGHT BY TYCO ELECTRONICS CORPORATION. ALL RIGHTS RESERVED.

LOC		DIBT		REVISIONS			
F	LTR	DESCRIPTION	DATE	BY	APP'D		
AF	50	B	REVISED PER ECR-06-010412	02NOV06	HMR	KR	

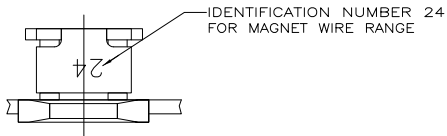

- CONTINUOUS STRIP ON REELS WITH TERMINALS LOCATED ON 5.59 ± 0.08 [.220 ± .003] CENTERS.
- SLOT TERMINATES A SINGLE MAGNET WIRE ONLY. COPPER REANGE: 0.91-1.15mm [#19-#17] AWG.
- AFTER INSERTION INTO PLASTIC HOLDER TAB PORTION MUST BE BENT OVER 45° TO 90° OR POTTED-IN TO PREVENT PULL-OUT WHEN MATING RECEPTACLE IS DISCONNECTED.
- PREPRODUCTION - FASR REQUIRED

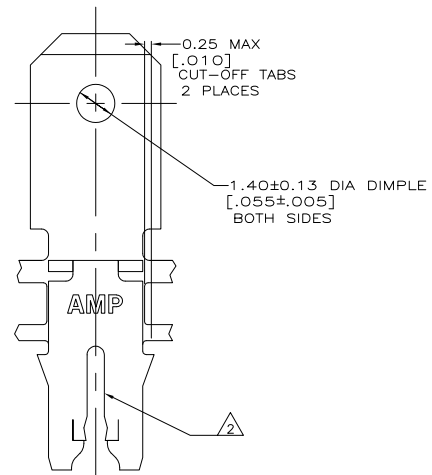
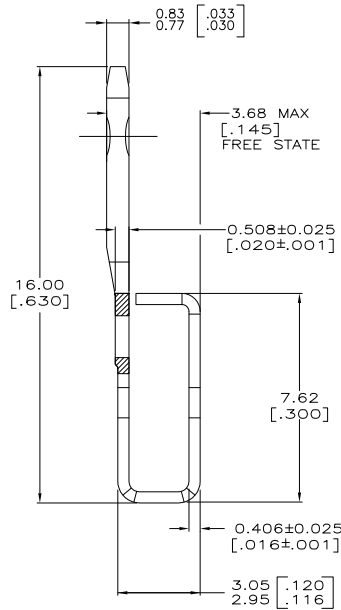
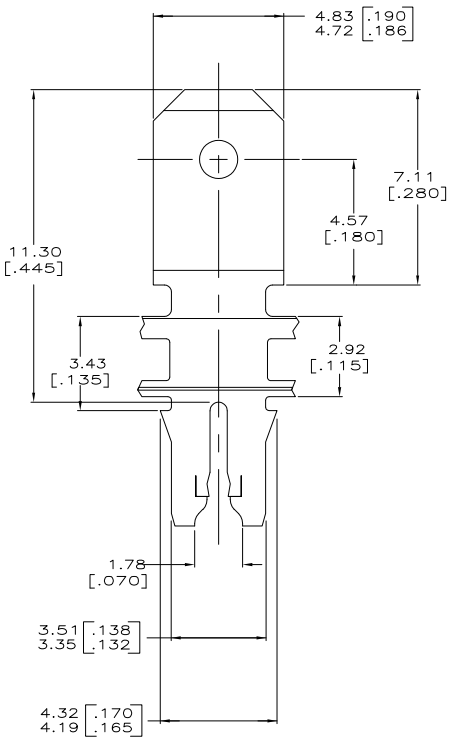

1742035-1
PART NUMBER

THIS DRAWING IS A CONTROLLED DOCUMENT.		DRW MICHAEL S. FEYER 09062003	Tyco Electronics Corporation	
DIMENSIONS: mm [INCHES]		CHK KURT A. RANDOLPH 09062003	Harrisburg, PA 17105-3608	
TOLERANCES UNLESS OTHERWISE SPECIFIED:		APP'D KURT A. RANDOLPH 09062003	NAME	
0 PLG ± .-	1 PLG ± .-	PRODUCT SPEC 108-2012	TERMINAL, TAB, 4.75[.187] FASTON,™ 300 SERIES MAG-MATE™	
2 PLG ± .025(010)	3 PLG ± .-	APPLICATION SPEC 114-2046	SIZE A2	CAGE CODE 00779
4 PLG ± .-	ANGLES ± .-	WEIGHT -	DRAWING ID C=1742035	RESTRICTED TO -
MATERIAL OR2 PRE-MILLED BRASS	FINISH 0.002032[.00080] MIN TIN PLATE	CUSTOMER DRAWING	SCALE 10:1	SHEET 1 of 1

AMP 1471-9 REV 31MM2000

1742035

A

B