

4

3

2

1

THIS DRAWING IS UNPUBLISHED. RELEASED FOR PUBLICATION
 (C) COPYRIGHT IS BY AMP INCORPORATED. ALL RIGHTS RESERVED.

REV	DATE	BY	APP'D	DESCRIPTION
A	30NOV99	MSF	KAR	RELEASE TO PRODUCTION 063A-0273-99

- 1 CONTINUOUS STRIP ON REELS WITH TERMINALS LOCATED ON 5.08±0.08 [.200±.003] CENTERS.
- △ SLOT ACCEPTS 0.29-0.35mm [#29-#27] AWG COPPER MAGNET WIRE 2 WIRES MAX OF THE SAME SIZE PER SLOT.
- △ IDENTIFICATION NUMBER 7 FOR WIRE SLOT SIZE.
- △ 0.00203 [.000080]-0.00381 [.000150] TIN PLATE OVER
0.00127 [.000050]-0.00254 [.000100] NICKEL UNDERPLATE.

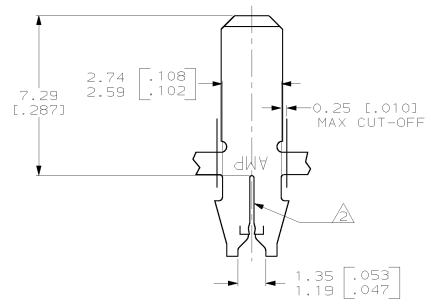
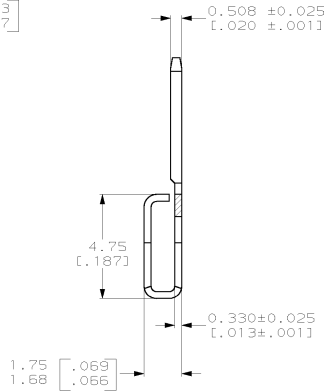
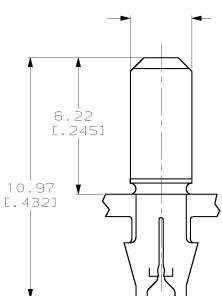
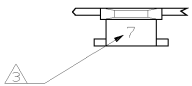

1217196-1
PART NUMBER

THIS DRAWING IS A CONTROLLED DOCUMENT.		DW: MICHAEL S. FEHNER DR: EURT A. RANDOLPH APP: EURT A. RANDOLPH DATE: 10/01/99	AMP AMP Incorporated Harrisburg, PA 17105-3608
DIMENSIONS: mm (INCHES)	DIMENSIONS: mm (INCHES)	PRODUCT SPEC: 108-2012 APPLICATION SPEC: 114-2059 WEIGHT: -	TITLE: TAB, 2.79[.110] FASTON™ 187 SERIES MAG-MATE™ CASE CODE: 1217196 SHEET: A200779 SCALE: 8:1 SHEET: 1 OF 1 REV: A
MATERIAL: H03 PRE-MILLED BRASS	FINISH: -	CUSTOMER DRAWING	RESTRICTED TO: -

1217196

1217196-1

PART NUMBER

RESTRICTED TO

SCALE

SHEET

OF

REV

A