

THIS DRAWING IS UNPUBLISHED. RELEASED FOR PUBLICATION 19
 © COPYRIGHT 19 BY AMP INCORPORATED. ALL INTERNATIONAL RIGHTS RESERVED.

LOC		DIST		ZONE		LTR		REVISIONS		DATE	APPO
AF	50	P	F					J	REVISED PER 063A-0088-00		HF/KR

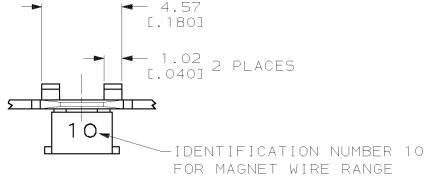

1 CONTINUOUS STRIP ON REELS WITH TERMINALS LOCATED ON 8.38±0.08 [.330±.003] CENTERS.
 SLOTTED TERMINALS A SINGLE OR DOUBLE MAGNET WIRE OF THE SAME SIZE AND TYPE; COPPER RANGE: 0.36-0.57 mm [#27-#23] AWG.

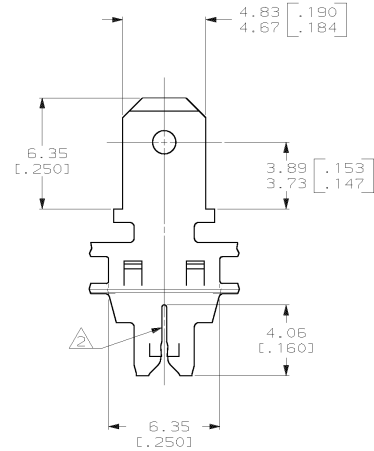
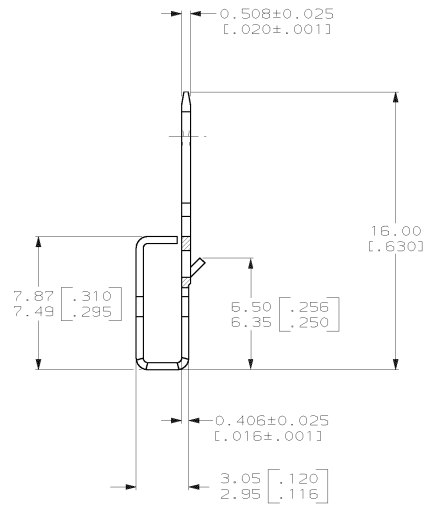
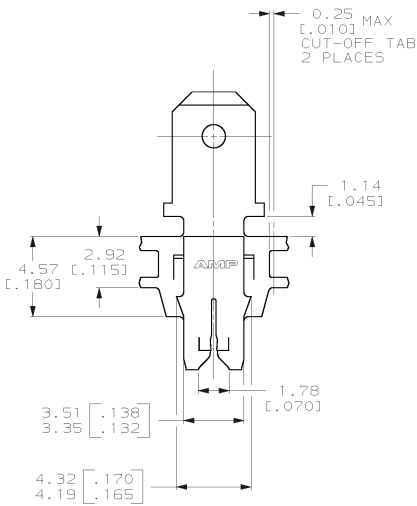

OBSOLETE		082 PRE-MILLED BRASS	63256-2
		4M PRE-MILLED BRASS	63256-1
		MATERIAL	PART NO
DO NOT SCALE PRINT. UNLESS SPECIFIED DIMENSIONS IN MM [INCHES] TOLERANCES ON ± 2 PLD DEC ± 0.25 [.010] 3 PLD DEC ± - ANGLES ± -		AMP AMP Incorporated Harrisburg, PA 17105-3608	
DR 28/MAR/94 R.R. BUCHHEISTER JR.		NAME	
CHK 04/APR/94 MICHAEL S. FEHER		TAB, 4.75 [.187] FASTON™ MAG-MATE™	
APPD 04/APR/94 NELSON E. NEFF		PRODUCT SPEC	
MATERIAL		108-2012	
SEE CHART		APPLICATION SPEC	
FINISH 0.002032 [.000080] MIN TIN PLATE		114-2094	
WEIGHT -		SIZE	CAGE CODE
		C	00779
		DRAWING NO	C=63256
		SCALE	6:1
		SHEET	1 OF 1

THIS DRAWING IS A CONTROLLED DOCUMENT FOR AMP INCORPORATED. IT IS SUBJECT TO CHANGE AND THE CONTROLLING ENGINEERING ORGANIZATION SHOULD BE CONTACTED FOR THE LATEST REVISION.