

4

3

2

1

THIS DRAWING IS UNPUBLISHED.  
 RELEASED FOR PUBLICATION  
 BY AMP INCORPORATED. ALL RIGHTS RESERVED.

LOC	DIST	REVISIONS		
F	LTR	DESCRIPTION	DATE	ENR
AF	50			
B		REVISED PER DG3A-0171-02	11APR02	MF KR

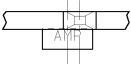

- 1 CONTINUOUS STRIP ON REELS WITH TERMINALS LOCATED ON  $5.08 \pm 0.08$  [.200 ± .003] CENTERS.
- ⚠ SLOT ACCEPTS 0.36-0.45mm [#27-#25] AWG COPPER MAGNET WIRE
- ⚠ IDENTIFICATION NUMBER 9 FOR WIRE SLOT SIZE.
- ⚠ 0.002032 [.000080] MIN TIN PLATE OVER 0.00254 [.000100] MIN COPPER UNDERPLATE.

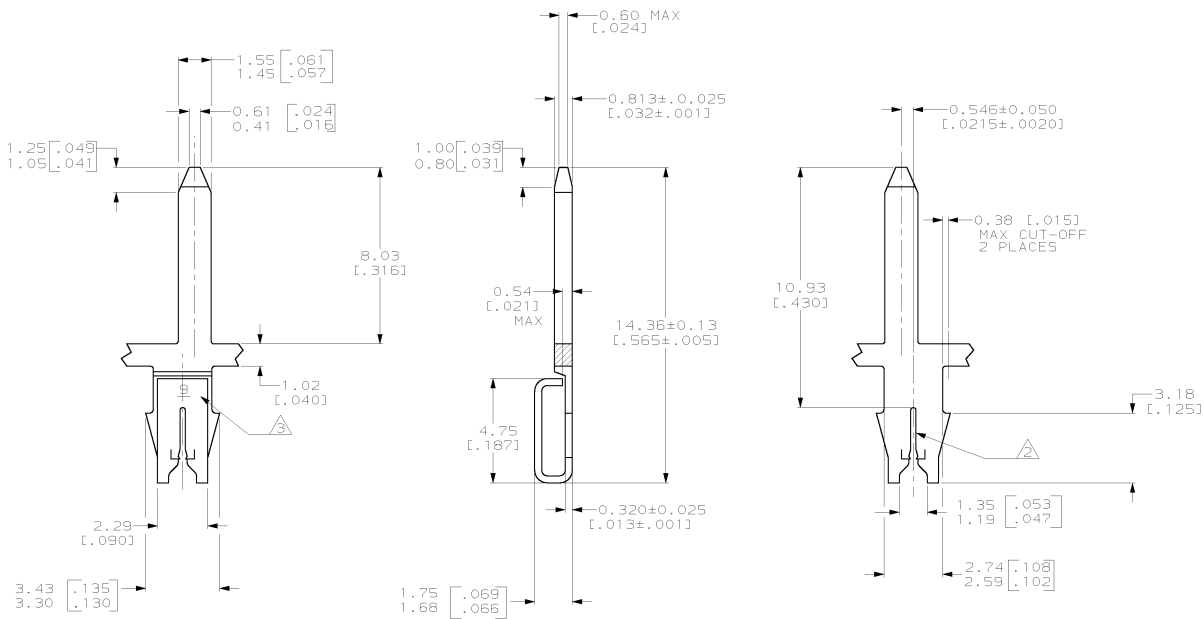

1217641-1
PART NUMBER

THIS DRAWING IS A CONTROLLED DOCUMENT.		DRAWN BY MICHAEL S. FEINER		AMP INCORPORATED Harrisburg, PA 17105-3608	
CHECKED BY KURT A. RANDOLPH		DATE 10/22/2001		AMP	
DESIGNED BY KURT A. RANDOLPH		DATE 10/22/2001		NAME TAB, 1.50 [.059] SERIES, RIGHT HAND, 187 SERIES MAG-MATE™	
PRODUCT SPEC 108-2012		APPLICATION SPEC 114-2069		STUR CASE CODE DRAWING NO. A200779	
MATERIAL #04 PRE-MILLED BRASS		FINISH		SCALE 8:1	
TOLERANCES UNLESS OTHERWISE SPECIFIED:		FRACTIONS DECIMALS		SHEET 1 OF 1	
Ø	± .005	± .005	± .005	REV B	
Ø	± .005	± .005	± .005		
Ø	± .005	± .005	± .005		
Ø	± .005	± .005	± .005		
Ø	± .005	± .005	± .005		
Ø	± .005	± .005	± .005		
Ø	± .005	± .005	± .005		
Ø	± .005	± .005	± .005		

AMP 1471-9 REV 11/2007  
 10-48R-02 08:57:59 amp0264 /home/amp0264/vdbteced