

DRAWING MADE IN AMERICAN PROJECTION

© 1970 BY AMP INCORPORATED. ALL RIGHTS RESERVED. AMP PRODUCTS COVERED BY PATENTS AND/OR PATENTS PENDING.

REVISIONS				
ZONE	LTR	DESCRIPTION	DATE	APPROVED
	0	NPS 70-0606 (REV 2)	12-30-70	FCJ
	A	REVISED TO AGREE WITH PROD. DWG	1-21-71	FCJ
	B	REV PER ECN P-6553	3-23-71	FCJ
	C	REVISED F-55A	5-12-71	FCJ
	D	REVISED P-6602	6-23-71	FCJ
	E	REV U-1790	5-28-72	JW

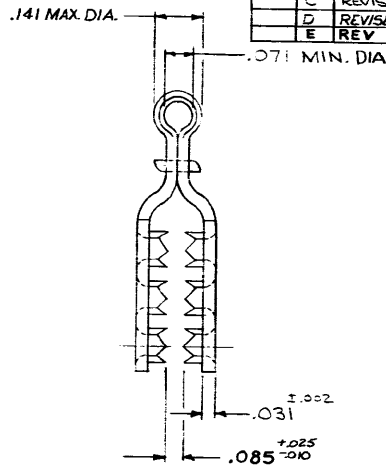
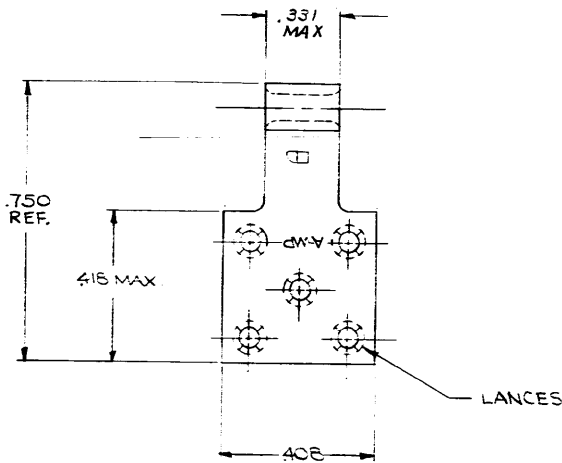

UNLESS OTHERWISE SPECIFIED DIMENSIONS ARE IN INCHES TOLERANCES ON: DECIMALS ± .008 ANGLES ± 5°	CONTRACT NO. 4	<b>AMP</b> AMP INCORPORATED HARRISBURG, PENNSYLVANIA
	DR. Jm Emminger 12-24-70 CHK. P. J. [Signature] 12-31-70 APPD. Swibel 12-31-70 REL. Adams 12-31-70 DGMN APPD. [Signature]	
MATERIAL COPPER (QQ-C-576) TIN PLATE (MIL-T-10727)	OTHER APPD.	SIZE CODE IDENT NO. NUMBER B 00779 52584
SCALE 4-1		SHEET 1 OF 1