

DRAWING MADE IN THIRD ANGLE PROJECTION
 THIS DRAWING IS UNPUBLISHED.
 © COPYRIGHT 19 BY AMP INCORPORATED. ALL INTERNATIONAL RIGHTS RESERVED.
 RELEASED FOR PUBLICATION
 , 19

LOC	DIST	ZONE	LTR	REVISIONS	DATE	APPRO
AF	50		C	REDRAWN PER AF-6482	4/11/90	PF/JJR

1 CONTINUOUS STRIP ON REELS

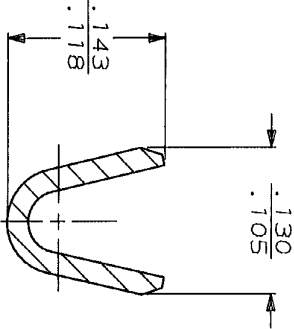
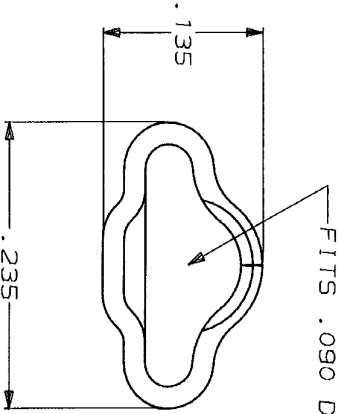
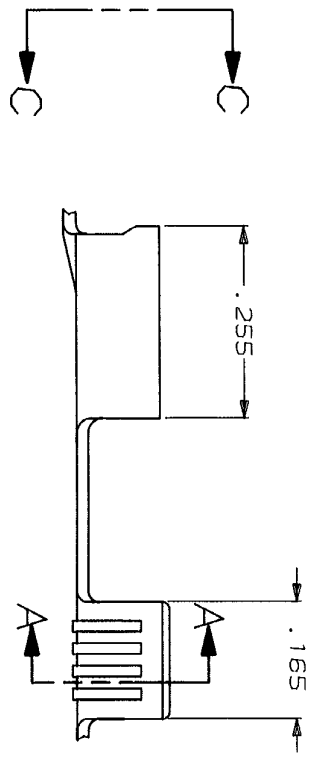
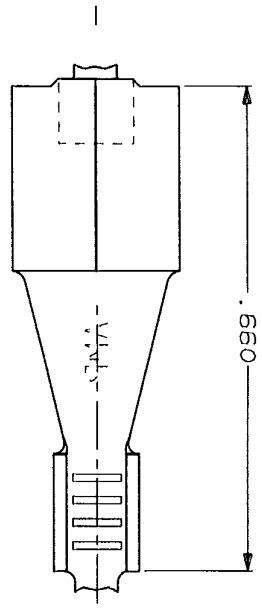

VIEW C-C
 SCALE 10:1

SECTION A-A
 SCALE 10:1

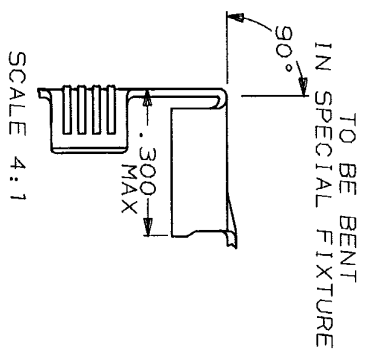

STRIP LENGTH ±.015	TYPE	WIDTH	HEIGHT ±.002	WIRE
.225	F	.090	.074	16
			.067	18
			.062	20

DO NOT SCALE PRINT. DIMENSIONS IN INCHES TOLERANCES ON: 2 PLG DEC ± .015 ANGLES ± 1°	DR 4/11/90 2 FORNEY CHK JR BUD APPD 4/11/90 APPD 6/11/90 R KUD PRODUCT SPEC
#3 HARD PHOS BRONZE	FINISH .000080 MIN TIN PL PER MIL-T-10727
WIRE BARREL CRIMP	DR 4/11/90 2 FORNEY CHK JR BUD APPD 4/11/90 APPD 6/11/90 R KUD PRODUCT SPEC
WIRE	DR 4/11/90 2 FORNEY CHK JR BUD APPD 4/11/90 APPD 6/11/90 R KUD PRODUCT SPEC

20-16 AWG	60733-1
WIRE RANGE	PART NO
AMP	AMP Incorporated Harrisburg, PA 17105-3608
PIN RECEPTACLE, .090 DIA	NAME
SIZE B	CAGE CODE
00779	60733
SCALE 6:1	DRAWING NO
	60733
	SHEET 1 OF 1

CUSTOMER DRAWING

AMP 1470-15 REV 11-89
 11 APR 1990 14.36.23 P7795 487846P712540M225U D14-82P1