

THIS DRAWING IS UNPUBLISHED
 ALL RIGHTS RESERVED

REV	DATE	DESCRIPTION	BY	CHK
AA	27			
VI		REVISED PER EDD-11-004917	11MMR11	RK HMR

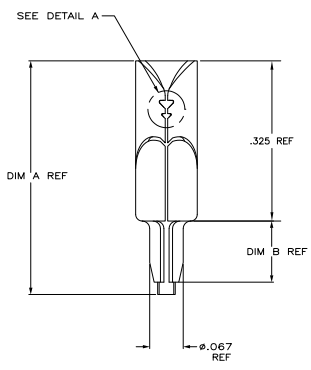

LOOSE PIECE
 -1, -3, -4, -6, & -8 ONLY

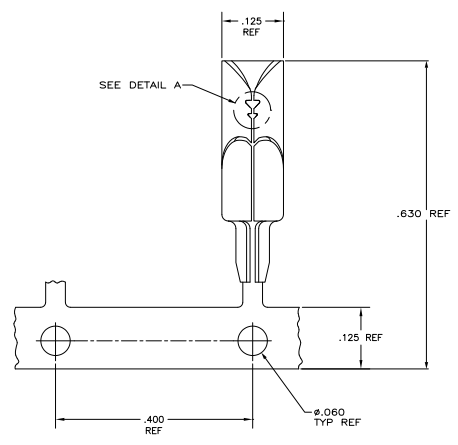

STRIP MOUNTED
 -2, -5 & -7 ONLY

- FOR USE IN PRINTED CIRCUIT BOARD, 3/64-1/8 THICK.
 - WIRE RANGE: 18-28 AWG (SOLID) OR (STRANDED) WIRE. MAX OUTSIDE DIA .086.
 - FURNISHED AS LOOSE PIECE OR STRIP MOUNTED BY SMALL END OF BARREL.
 - TERMINAL SHALL ACCOMMODATE ONE OR TWO WIRES OF THE SAME TYPE AND WITHIN PLUS OR MINUS ONE WIRE GAGE SIZE. EXAMPLE:
24 AWG MAY BE MIXED WITH EITHER 26 OR 22 AWG.
 - RECOGNIZED UNDER COMPONENT RECOGNITION PROGRAM OF UNDERWRITERS LABORATORIES INC., FILE NO. E-28476.
 - FOR 18-22 AWG WIRE USE INSERTION TOOL, PART NO. 552714-1 AND FOR 24-28 AWG WIRES USE PART NO. 552714-3.
- ⚠ WHEN USING TEFLON INSULATED WIRES USE 552699-1, -2 OR -3 ONLY.
- ⚠ WHEN USING 28 AWG SOLID, TWO WIRES PER TERMINAL, USE 552699-4, -5, -6, -7 OR -8 ONLY.

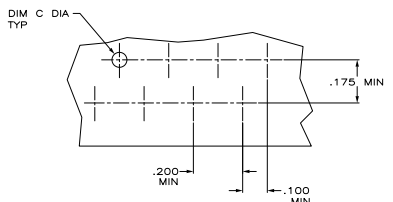
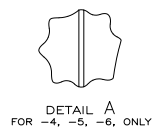
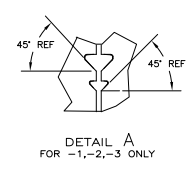

SUGGESTED PRINTED CIRCUIT BOARD MOUNTING DIMENSIONS

TERMINAL PART NO.	WIRE RANGE	WIRE DIA	WIRE THICKNESS	PC BOARD THICKNESS	DESCRIPTION	PART NO.
230549-1		.483	.062-.125		SUPERSEDED BY -4	552699-6
1-453973-4		.458	.062-.094		SAME AS -2 EXCEPT AS SHOWN IN DETAIL A	552699-5
2-453973-1		.483	.094-.125		SUPERSEDED BY -1	552699-3
230549-1		.458	.062-.094		SAME AS -1 EXCEPT AS SHOWN IN DETAIL A	552699-4
230549-1		.458	.062-.094		SUPERSEDED BY -1	552699-3
1-453973-4		.458	.062-.094		AS SHOWN, STRIP MOUNTED	552699-2
2-453973-1		.483	.094-.125		AS SHOWN, LOOSE PIECE	552699-1
230549-1		.458	.062-.094		AS SHOWN, LOOSE PIECE	552699-1

TERMINAL PART NO.	WIRE RANGE	WIRE DIA	WIRE THICKNESS	PC BOARD THICKNESS	DESCRIPTION	PART NO.
230549-1		.483	.062-.125		SUPERSEDED BY -4	552699-6
1-453973-4		.458	.062-.094		SAME AS -2 EXCEPT AS SHOWN IN DETAIL A	552699-5
2-453973-1		.483	.094-.125		SUPERSEDED BY -1	552699-3
230549-1		.458	.062-.094		SAME AS -1 EXCEPT AS SHOWN IN DETAIL A	552699-4
230549-1		.458	.062-.094		SUPERSEDED BY -1	552699-3
1-453973-4		.458	.062-.094		AS SHOWN, STRIP MOUNTED	552699-2
2-453973-1		.483	.094-.125		AS SHOWN, LOOSE PIECE	552699-1
230549-1		.458	.062-.094		AS SHOWN, LOOSE PIECE	552699-1

TERMINAL PART NO.	WIRE RANGE	WIRE DIA	WIRE THICKNESS	PC BOARD THICKNESS	DESCRIPTION	PART NO.
230549-1		.483	.062-.125		SUPERSEDED BY -4	552699-6
1-453973-4		.458	.062-.094		SAME AS -2 EXCEPT AS SHOWN IN DETAIL A	552699-5
2-453973-1		.483	.094-.125		SUPERSEDED BY -1	552699-3
230549-1		.458	.062-.094		SAME AS -1 EXCEPT AS SHOWN IN DETAIL A	552699-4
230549-1		.458	.062-.094		SUPERSEDED BY -1	552699-3
1-453973-4		.458	.062-.094		AS SHOWN, STRIP MOUNTED	552699-2
2-453973-1		.483	.094-.125		AS SHOWN, LOOSE PIECE	552699-1
230549-1		.458	.062-.094		AS SHOWN, LOOSE PIECE	552699-1