

SIGN	DATE	DESCRIPTION	APPROVER
THIS IS CAD DRAWING, DO NOT REVISE MANUALLY!!!			

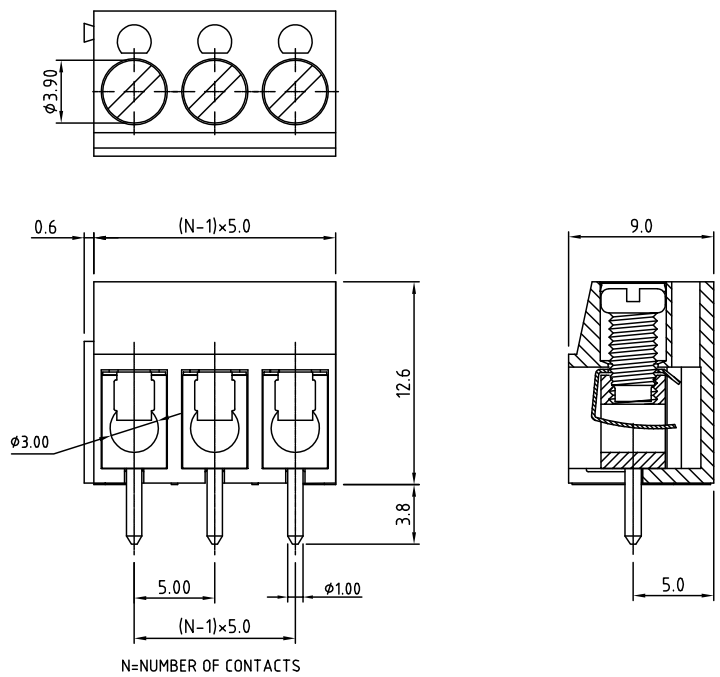

P.C.B LAYOUT

- Material**
- Terminal body
  - (metal housing): Brass(CuZn)
  - Terminal screw: Steel Zinc plating "-" slot type
  - Wire guard: Stainless steel
  - Surface of solder tail: Tin plated
  - Insulator (housing): Thermoplastic (UL94V-0)

- Electrical UL/CSA/VDE**
- Voltage rating: 250VAC/250VAC/250VAC
  - Current rating: 16A
  - Wire range: 1.0-2.5mm<sup>2</sup>
  - Solid wire(AWG): 14-26/14-22
  - Stranded wire(AWG): 14-26/14-22
  - Torque: 2.6Lb-In/4Kgf.cm/0.6Nm
  - Screw: M3
  - Wire strip length: 6-7mm
  - Withstanding Voltage: 1.5KV/1.5KV/2KV
  - Operating temperature: -30°C to +105°C
  - Soldering temperature: 250°C±10°C/5 Sec
  - Safety Approval:



RoHS Compliant

PART NUMBER:

**OSTTAXX0161**

No. of Poles	COLOR
02 2 Poles	0: Black
03 3 Poles	5: Green
...	6: Blue (Standard)
24 24 Poles	8: Grey



THESE DRAWINGS AND SPECIFICATIONS ARE THE PROPERTY OF ON-SHORE TECHNOLOGY, INC. AND SHALL NOT BE REPRODUCED, COPIED OR USED IN ANY MANNER WITHOUT THE PRIOR WRITTEN CONSENT OF ON-SHORE TECHNOLOGY, INC.

TITLE		OSTTA - 5.0mm series 1-Interlock	
PART NO.	OSTTAXX0161	DWG NO.	OSTTAXX0161.DWG
APPROVED	CHECKED	DESIGNED	DRAWN
Shi Jun 2006.10.19	Marvin 2006.10.19	Marvin 2006.10.19	Marvin 2006.10.19
SHEET: 01/01		REV: D	
UNIT: mm		Tolerance	
SCALE: NONE		X.	±0.50
		X.X	±0.30
		X.XX	±0.10
		X*	±1*