

INTEGRATED CONNECTOR MODULES

0833-2X6R-55 Power over Ethernet MagJack® 2 x 6

ELECTRICAL CHARACTERISTICS @ 25°C

URNS RATIO	1CT : 1CT ±2%
CL @ 0.1V, 100KHz 8mA DC BIAS	350µH MIN.
INSERTION LOSS 100KHz TO 100MHz	-1.5 dB MAX.
RETURN LOSS (MIN.) 2MHz-30MHz 60MHz-80MHz	16 dB MIN. 10 dB MIN.
LEAKAGE INDUCTANCE PRIMARY W/ SECONDARY SHORTED	0.25µH MAX. @ 1MHz
D.C. RESISTANCE (9-8)=(7-6) (RJ1-RJ2)=(RJ3-RJ6)	1.4 ΩHM . 1.0 ΩHM .
INTERWINDING CAPACITANCE PER CHANNEL (PRI. to SEC.)	40 pF MAX.
XTALK 100KHz TO 100MHz	-30 dB MIN.
HIPOT	2250 VDC

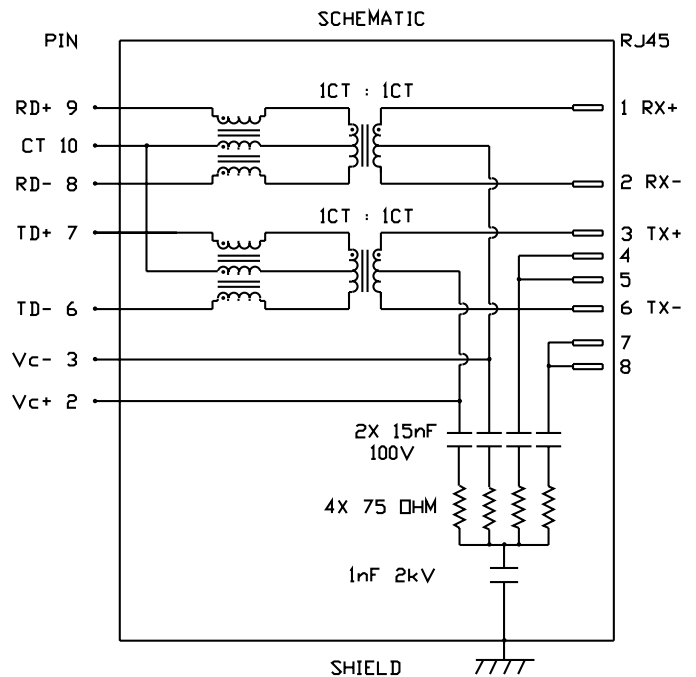

INTEGRATED CONNECTOR MODULES

0833-2X6R-55 Power over Ethernet MagJack® 2 x 6

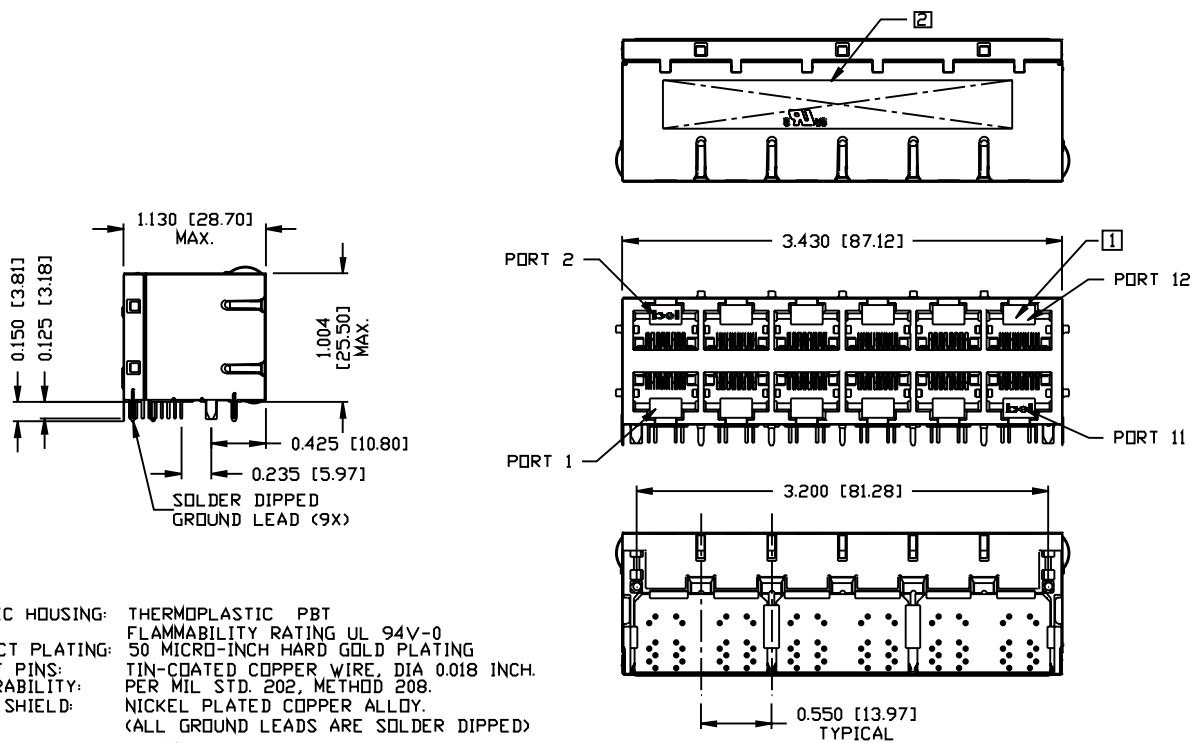

NOTES:

PLASTIC HOUSING: THERMOPLASTIC PBT
 FLAMMABILITY RATING UL 94V-0
 CONTACT PLATING: 50 MICRO-INCH HARD GOLD PLATING
 OUTPUT PINS: TIN-COATED COPPER WIRE, DIA 0.018 INCH.
 SOLDERABILITY: PER MIL STD. 202, METHOD 208.
 METAL SHIELD: NICKEL PLATED COPPER ALLOY.
 (ALL GROUND LEADS ARE SOLDER DIPPED)

- ① JACK CAVITY CONFORMS TO FCC RULES AND REGULATIONS, PART 68 SUBPART F.
- ② MARK PART WITH MFG LOGO, MFG NAME, PART NUMBER, AND DATE CODE.

UL RECOGNIZED - FILE #E196366 AND E169987.

INTEGRATED CONNECTOR MODULES

0833-2X6R-55 Power over Ethernet MagJack® 2 x 6

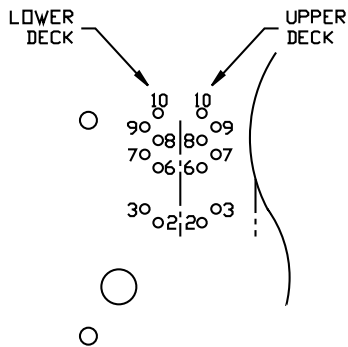

PIN-OUT INFORMATION
(COMPONENT SIDE VIEW)

10	COMMON CT
9	RD+
8	RD-
7	TD+
6	TD-
5	NO PIN
4	NO PIN
3	Vc-
2	Vc+
1	NO PIN

UNUSED PIN LOCATIONS MUST BE REMOVED TO ENSURE 2KV ISOLATION.

PORT ASSIGNMENT
(COMPONENT SIDE VIEW)

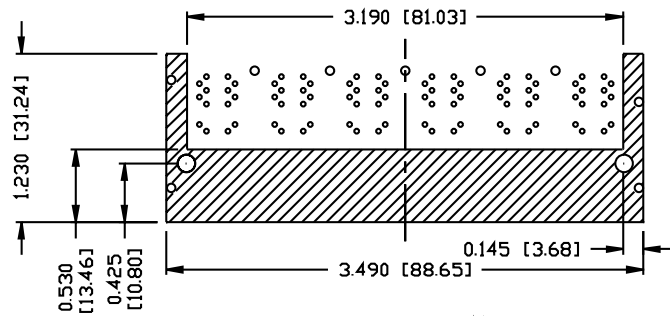
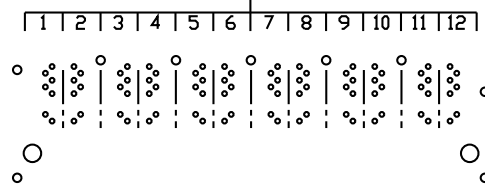

THE SHADED AREA OF BOTTOM SIDE OF PART MAY BE COVERED BY METAL SHIELD.

INTEGRATED CONNECTOR MODULES

0833-2X6R-55 Power over Ethernet MagJack® 2 x 6

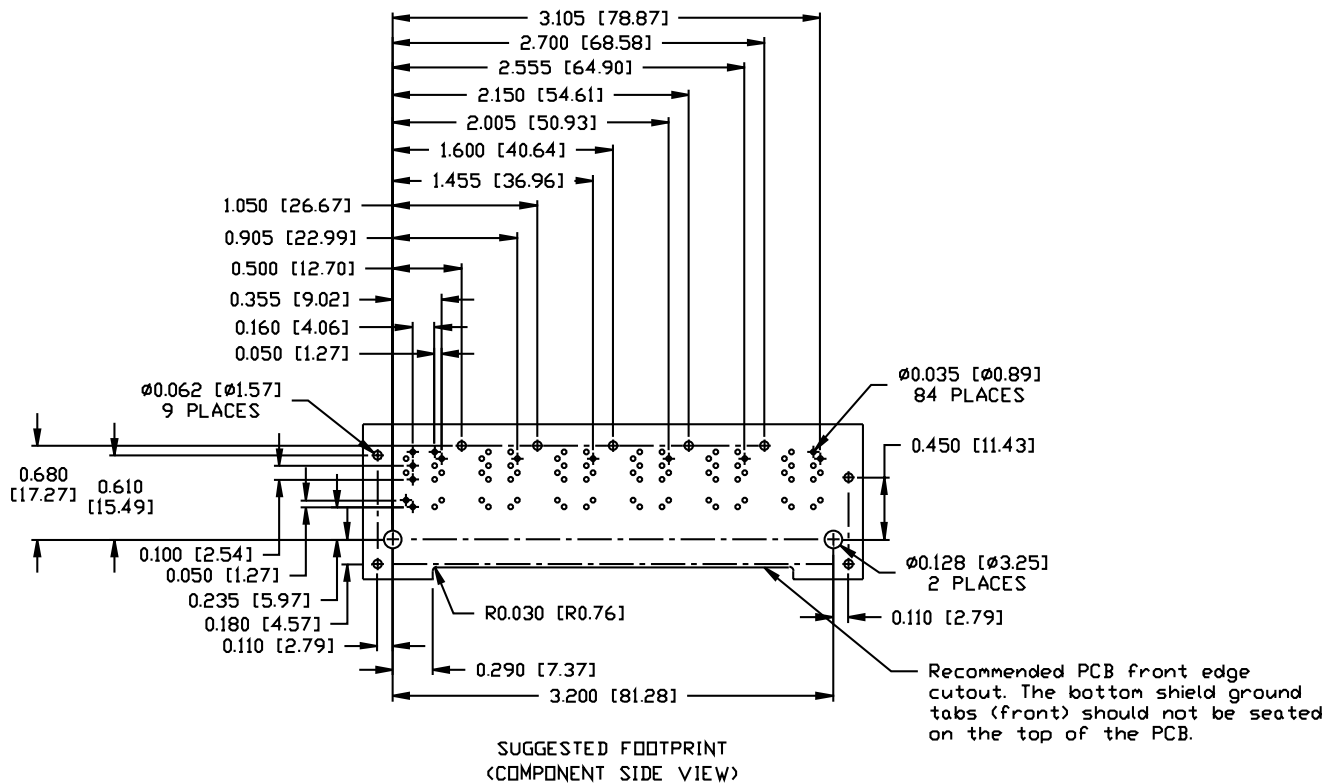

INTEGRATED CONNECTOR MODULES

0833-2X6R-55 Power over Ethernet MagJack® 2 x 6

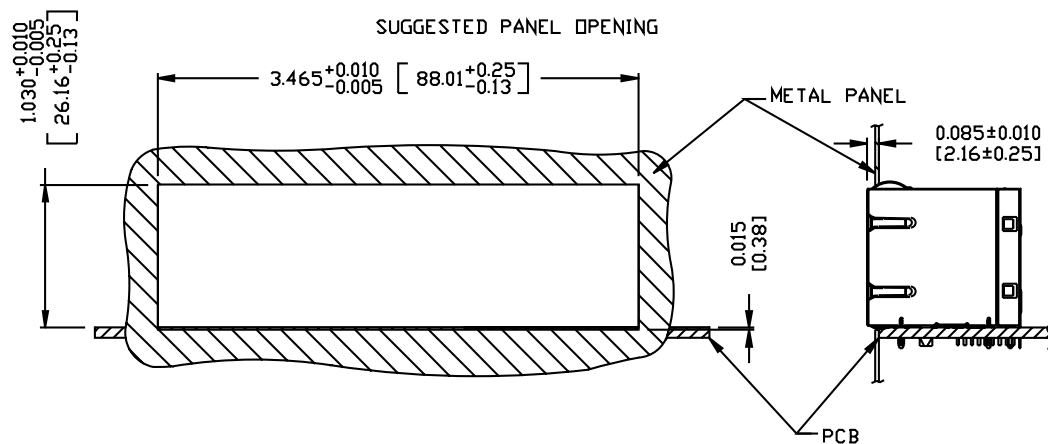

NOTE:

THE DISTANCE OF PANEL INSIDE SURFACE RELATIVE TO FRONT SURFACE OF PART IS ONLY A SUGGESTION. IN CASE THIS DISTANCE IS DIFFERENT, THE REQUIRED PANEL OPENING DIMENSIONS CHANGE ACCORDINGLY.

PACKING INFORMATION

PACKING TRAY : 0200-9999-A9 (TOP)
0200-9999-A8 (BOTTOM)

PACKING QUANTITY : 15 PCS FINISHED GOODS PER TRAY
7 TRAY (105 PCS FINISHED GOODS) PER CARTON BOX

NOTE : CARDBOARDS ARE PLACED BETWEEN LAYERS OF PACKING TRAY INSIDE CARTON BOX
(INCLUDE THE UPPERMOST AND LOWERMOST TRAY)