

**Stacked Modular Jacks (Continued)**

Side Entry (RA),  
Press Fit/Offset

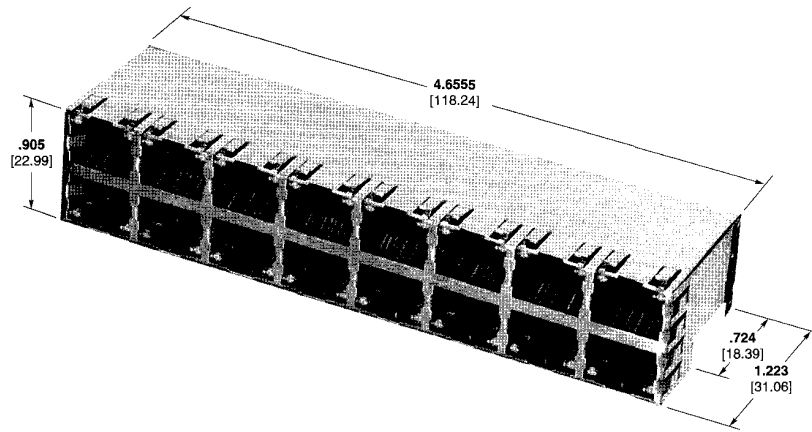
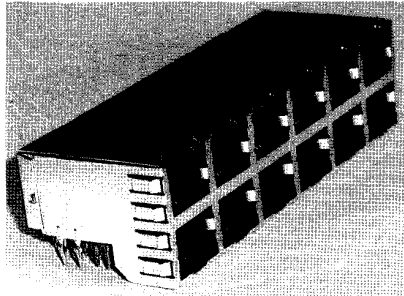

No. of Ports	Part Number	Positions/Contacts	LEDs	Shielded	Performance	Panel Stops	Inverted	Ground Options
2 x 4	1368077-2	8/8	Without	Yes	Cat 5	Without	N/A	Panel and PCB
2 x 4	1368062-1	8/8	With	Yes	Cat 5	Without	N/A	Panel and PCB
2 x 4	1368077-1	8/8	Without	Yes	Cat 5	Without	N/A	Panel and PCB
2 x 6	1368035-1	8/8	With	Yes	Cat 5	Without	N/A	Panel and PCB
2 x 6	1368116-2	8/8	With	Yes	Cat 5	Without	N/A	Panel and PCB
2 x 8	1116689-1	8/8	Without	Yes	Cat 5	Without	N/A	Panel and PCB
2 x 8	1116317-2	8/8	With	Yes	Cat 5	Without	N/A	Panel and PCB

Note: Consult Tyco Electronics Customer Drawing for additional Part Numbers.

Stacked Modular Jacks

RJ45, Dual USB

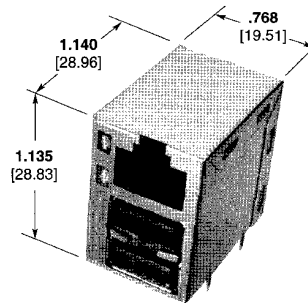

No. of Ports	Part Number	Positions/Contacts	LEDs	Shielded	Performance	Panel Stops	Inverted	Ground Options
2 x 1	1116151-2	8/8	With	Yes	Cat 5	Without	No	PCB
2 x 1	1116151-3	8/8	Without	Yes	Cat 5	Without	No	PCB
2 x 1	1116640-2	8/8	With	Yes	Cat 5	Without	No	PCB

Note: Consult Tyco Electronics Customer Drawing for additional Part Numbers.