

THE INFORMATION CONTAINED HEREIN IS CONSIDERED 'PROPRIETARY' TO BEL FUSE INC. AND SHALL NOT BE COPIED, REPRODUCED OR DISCLOSED WITHOUT THE WRITTEN APPROVAL OF BEL FUSE INC.



ELECTRICAL CHARACTERISTICS @ 25°C

OPERATING TEMPERATURE RANGE: 0°C TO +70°C

- 1.0 TURNS RATIO: (P3-P2):(J2-J1) : 1CT:1CT±3%
 (P5-P4):(J6-J3) : 1CT:1CT±3%
 (P7-P6):(J5-J4) : 1CT:1CT±3%
 (P9-P8):(J8-J7) : 1CT:1CT±3%
- 2.0 INDUCTANCE: (P3-P2):(P5-P4) : 350uH MIN. @ 0.1V, 100kHz, 8mA DC BIAS
 (P7-P6):(P9-P8) : 350uH MIN. @ 0.1V, 100kHz, 8mA DC BIAS
- 3.0 LEAKAGE INDUCTANCE: P3-P2(WITH J2 AND J1 SHORT) : 0.3uH MAX. @ 1 MHz
 P5-P4(WITH J6 AND J3 SHORT) : 0.3uH MAX. @ 1 MHz
 P7-P6(WITH J5 AND J4 SHORT) : 0.3uH MAX. @ 1 MHz
 P9-P8(WITH J8 AND J7 SHORT) : 0.3uH MAX. @ 1 MHz
- 4.0 INTERWINDING CAPACITANCE: (P3-P2):(J2-J1) : 85pF MAX @ 1MHz
 (P5-P4):(J6-J3) : 85pF MAX @ 1MHz
 (P7-P6):(J5-J4) : 85pF MAX @ 1MHz
 (P9-P8):(J8-J7) : 85pF MAX @ 1MHz
- 5.0 DC RESISTANCE:(J6-J3)=(J2-J1)=(J4-J5)=(J7-J8) : 1.2 OHMS MAX
- 6.0 RETURN LOSS:1MHz TO 30MHz : 18dB MIN.
 30MHz TO 80MHz : 12-20 LOG($\frac{F}{80MHz}$)
- 7.0 DIELECTRIC WITHSTAND:(J1,J2) TO (P2,P3) ; (J5,J4) TO (P6-P5) : 1500 Vrms
 (J3,J6) TO (P7,P4) ; (J8,J7) TO (P9, P8) : 1500 Vrms
- 8.0 INSERTION LOSS:RS=RL=100 ohms : 1.1 dB MAX
 100KHz TO 100MHz
- 9.0 RISE TIME:RS=100 OHMS AND RL = 100 OHMS : 3.0 nS MAX
 OUTPUT VOLTAGE = 1 V peak : 3.0 nS MAX
 PULSE WIDTH= 112nS
- 10.0 CROSS TALK:1-60 MHz : 35 dB MIN
 60-100 MHz : 25 dB MIN
- 11.0 COMMON TO COMMON MODE ATTENUATION:1MHz TO 100MHz : 35dB TYP

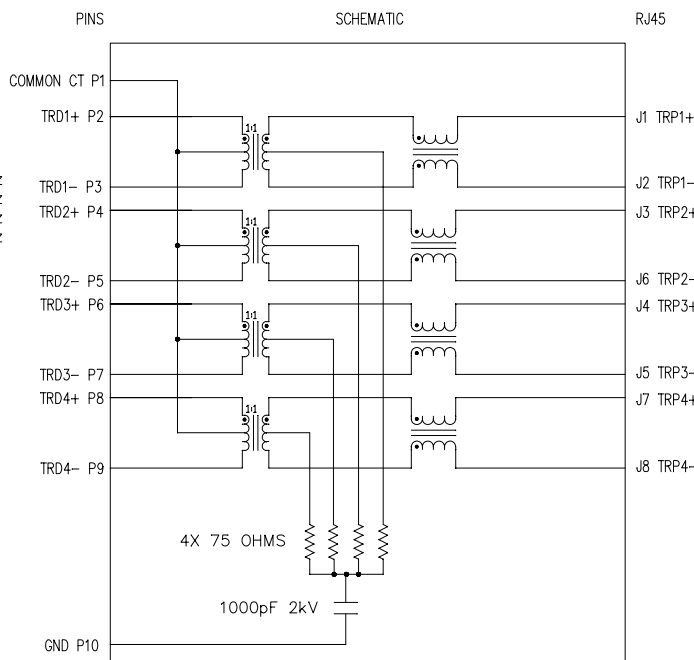

NOTES: PINS WITHOUT ELECTRICAL CONNECTION ARE OMITTED.

ORIGINATED BY	DATE	TITLE	PART NO. / DRAWING NO.	STANDARD DIM.	[] METRIC DIM. AS REFERENCE	 COMPONENTS OF A CONTROLLED COPY	
Bain Liu	10-21-08	MagJack® 10/100/1000BT TAB DOWN, SHIELDED	SI-61001-F	TOL. IN INCH	UNIT : INCH [mm]		REV. : B
DRAWN BY	DATE		FILE NAME	.X .XX .XXX	SCALE : N/A		SIZE : A4
L.W. Yuan	10-21-08	SI-61001-F.DWG	±0.005		PAGE : 1		

REV A1 06-30-2008

This document is electronically generated. This is a controlled copy if used internally

THE INFORMATION CONTAINED HEREIN IS CONSIDERED "PROPRIETARY" TO BEL FUSE INC. AND SHALL NOT BE COPIED, REPRODUCED OR DISCLOSED WITHOUT THE WRITTEN APPROVAL OF BEL FUSE INC.

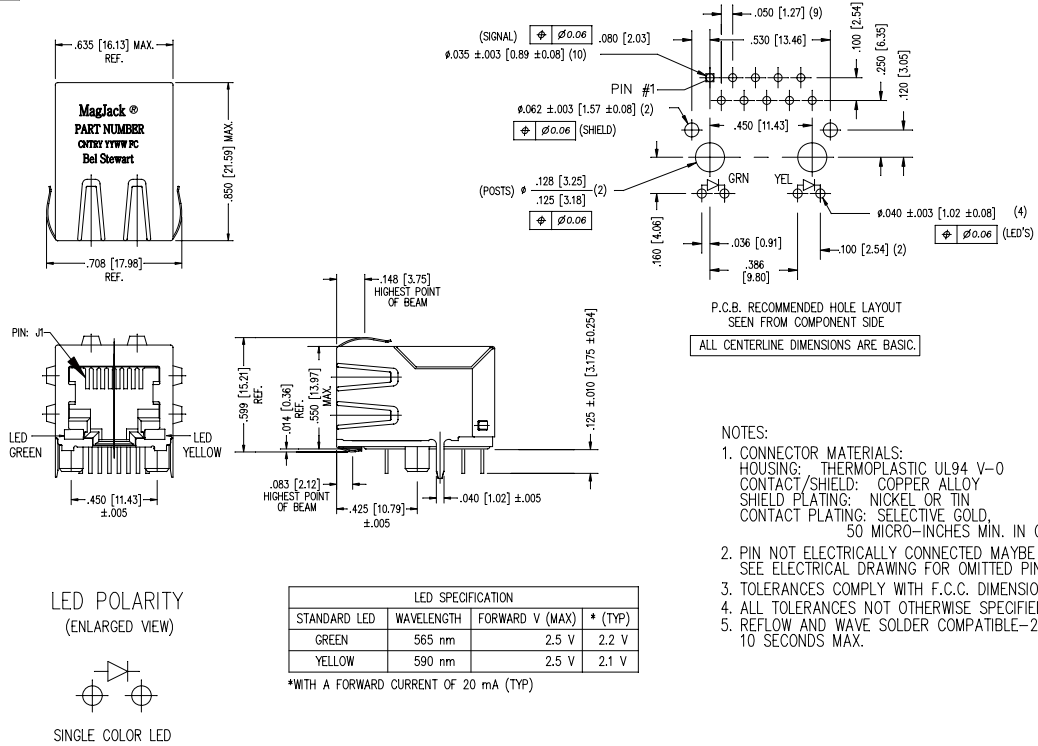

- NOTES:
- CONNECTOR MATERIALS:
HOUSING: THERMOPLASTIC UL94 V-0
CONTACT/SHIELD: COPPER ALLOY
SHIELD PLATING: NICKEL OR TIN
CONTACT PLATING: SELECTIVE GOLD,
50 MICRO-INCHES MIN. IN CONTACT AREA.
 - PIN NOT ELECTRICALLY CONNECTED MAYBE OMITTED.
SEE ELECTRICAL DRAWING FOR OMITTED PINS.
 - TOLERANCES COMPLY WITH F.C.C. DIMENSION REQUIREMENTS.
 - ALL TOLERANCES NOT OTHERWISE SPECIFIED TO BE ±.005 [0.13]
 - REFLOW AND WAVE SOLDER COMPATIBLE-260°C FOR 10 SECONDS MAX.

ORIGINATED BY	DATE	TITLE
Bain Liu	10-21-08	MagJack®
DRAWN BY	DATE	10/100/1000BT TAB DOWN, SHIELDED
L.W. Yuan	10-21-08	

PART NO. / DRAWING NO.	SI-61001-F
FILE NAME	SI-61001-F.DWG

STANDARD DIM. TOL. IN INCH	[] METRIC DIM. AS REFERENCE
.X	UNIT : INCH [mm]
.XX	REV. : B
.XXX	SCALE : N/A
±0.005	SIZE : A4
	PAGE : 2

UNIT : INCH [mm]	REV. : B
SCALE : N/A	SIZE : A4
PAGE : 2	



REV A1 06-30-2008

This document is electronically generated. This is a controlled copy if used internally

THE INFORMATION CONTAINED HEREIN IS CONSIDERED "PROPRIETARY" TO BEL FUSE INC. AND SHALL NOT BE COPIED, REPRODUCED OR DISCLOSED WITHOUT THE WRITTEN APPROVAL OF BEL FUSE INC.

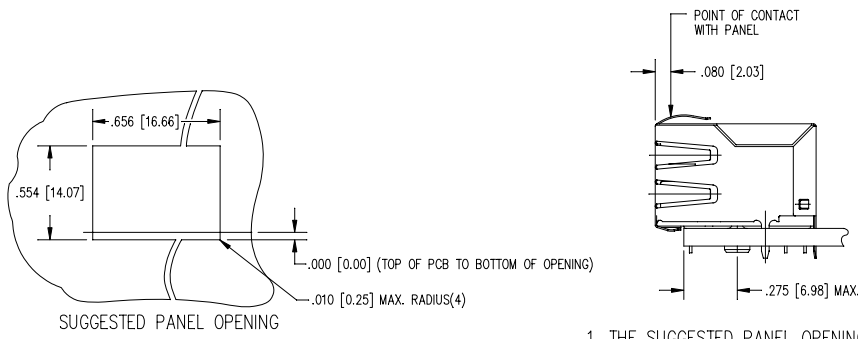

1. THE SUGGESTED PANEL OPENING IS INTENDED TO GIVE THE USER THE ABILITY TO HAVE REASONABLE JACK / PANEL CLEARANCES YET MAINTAIN RELIABLE GROUNDING CAPABILITY.
2. ALL TOLERANCES NOT OTHERWISE SPECIFIED TO BE ± 0.005 [0.13]

ORIGINATED BY Bain Liu	DATE 10-21-08	TITLE MagJack® 10/100/1000BT TAB DOWN, SHIELDED	PART NO. / DRAWING NO. SI-61001-F	STANDARD DIM. TOL. IN INCH	[] METRIC DIM. AS REFERENCE	bel COMPONENTS & CONSTRUCTED FLXSMITH
DRAWN BY L.W. Yuan	DATE 10-21-08		FILE NAME SI-61001-F.DWG	.X .XX .XXX ±0.005	UNIT : INCH [mm] SCALE : N/A PAGE : 3	

REV A1 06-30-2008

This document is electronically generated. This is a controlled copy if used internally