

Copyright FCI.

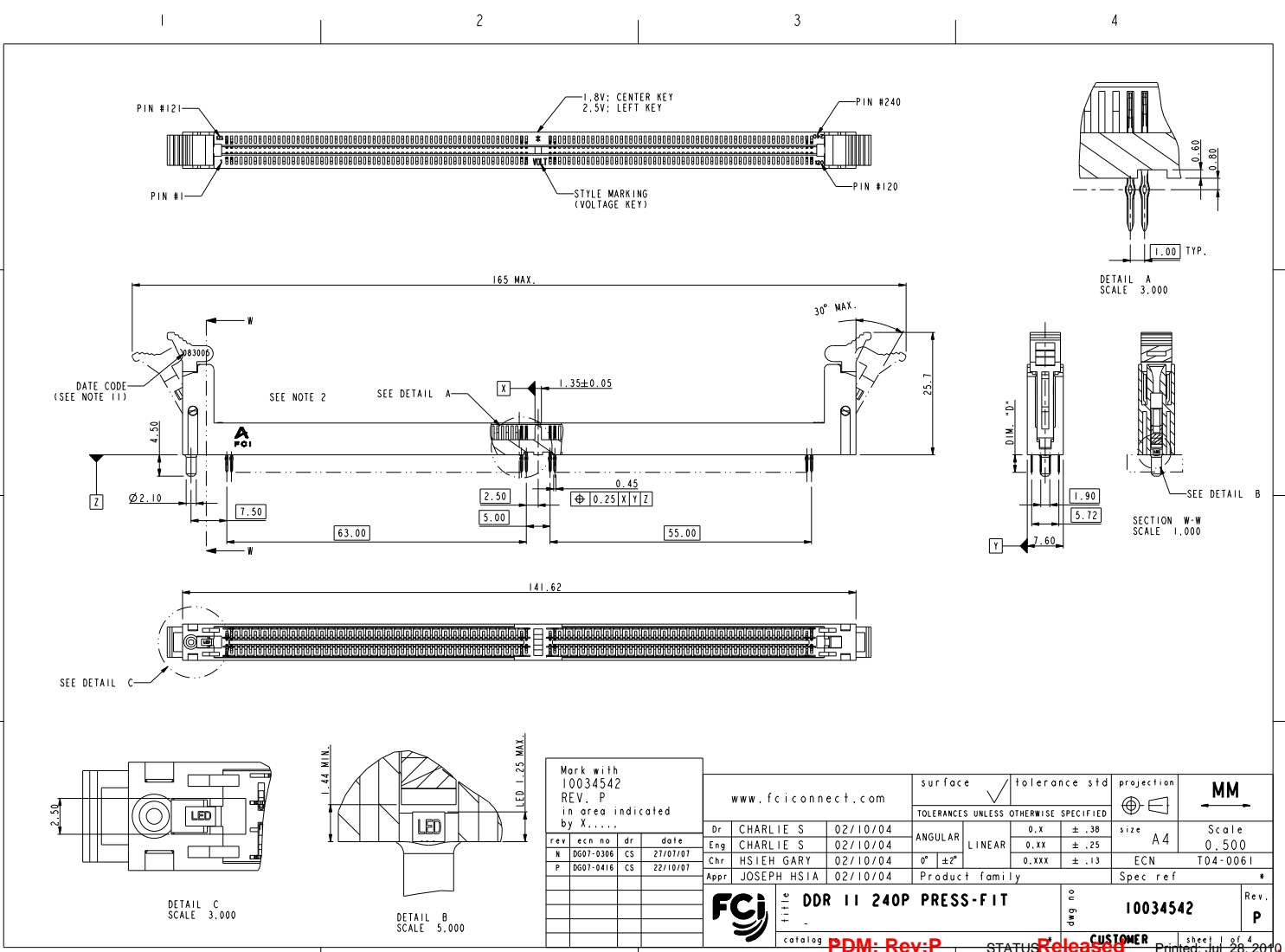

Mark with  
10034542  
REV. P  
in area indicated  
by X.....

rev	ecn no	dr	date
N	DG07-0306	CS	27/07/07
P	DG07-0416	CS	22/10/07

www.fciconnect.com		surface	tolerance std	projection	MM
		ANGULAR	0.x ±.38	size	Scale
		LINEAR	0.xx ±.25	A4	0.500
		0° ±2°	0.xxx ±.13	ECN	T04-0061
Product family				Spec ref	
<b>FCI</b> title catalog		<b>DDR II 240P PRESS-FIT</b>		dwg no <b>10034542</b>	
		PDM: Rev:P		STATUS Released	
		CUSTOMER		sheet 1 of 4 Rev. P	

REV. P - 2004-06-17

Printed: Jul 28, 2010

Copyright FCI.

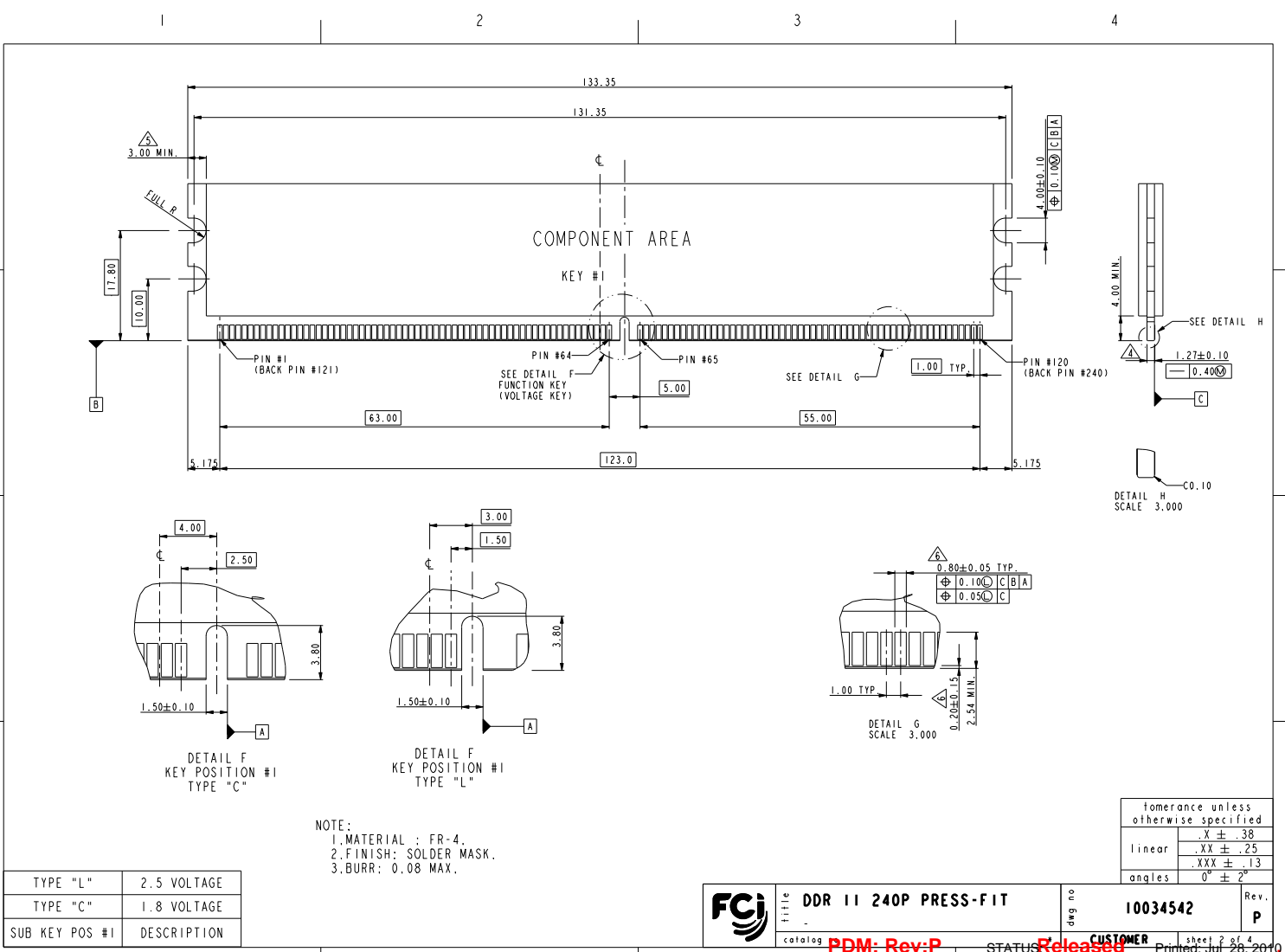

SUB KEY POS #1	DESCRIPTION
TYPE "L"	2.5 VOLTAGE
TYPE "C"	1.8 VOLTAGE

NOTE:  
 1. MATERIAL : FR-4.  
 2. FINISH: SOLDER MASK.  
 3. BURR: 0.08 MAX.

tolerance unless otherwise specified	
linear	.X ± .38
	.XX ± .25
	.XXX ± .13
angles	0° ± 2°

	<b>DDR II 240P PRESS-FIT</b>	dwg no	<b>10034542</b>	Rev.	<b>P</b>
	catalog	<b>PDM: Rev:P</b>	STATUS	<b>Released</b>	CUSTOMER

REV 7 - 2000-06-17

sheet 2 of 4  
 Printed: Jul 28, 2010

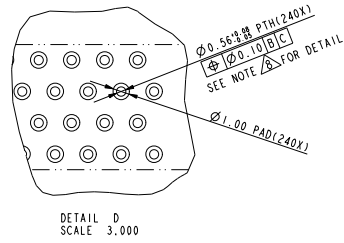
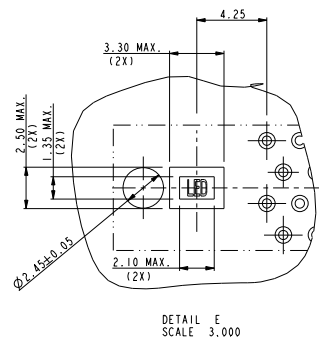
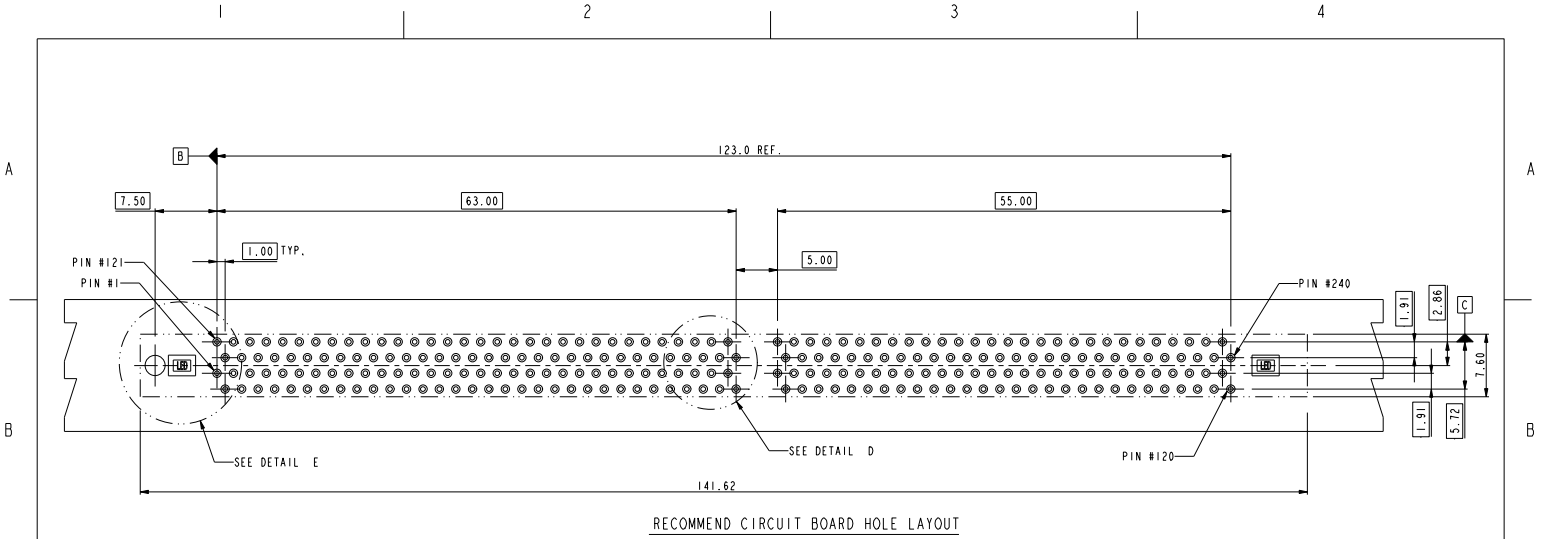

tolerance unless otherwise specified	
linear	.X ± .38
	.XX ± .25
	.XXX ± .13
angles	0° ± 2°

	title	DDR II 240P PRESS-FIT	dwg no	10034542	Rev.	P
	catalog	PDM: Rev:P	STATUS	Released	CUSTOMER	sheet 3 of 4

REV 7 - 2006-06-17

Printed: Jul 28, 2010

Copyright FCJ.

1 2 3 4

10034542-□ □ □ □ □

STYLE: MECHANICAL KEYING  
 1 : 1.8 VOLT. W/CENTER KEY #1  
 2 : 2.5 VOLT. W/LEFT KEY #1

PLATING

REVISE  
 0

CODE	DIM. "D"
0	3.30
1	3.70
2	4.20

CODE	CONTACT	TAIL AREA	UNDERPLATE	CODE	CONTACT	TAIL AREA	UNDERPLATE
2	15u" (0.38um) MIN. GOLD	35u"-100u" Tin PLATING	50u" (1.27um) MIN. NICKEL OVERALL	2B	15u" (0.38um) MIN. GOLD	35u"-100u" Tin/Lead PLATING	50u" (1.27um) MIN. NICKEL OVERALL
3	30u" (0.76um) MIN. GOLD			3B	30u" (0.76um) MIN. GOLD		
4	3u" (0.076um) MIN. GOLD			4B	3u" (0.076um) MIN. GOLD		
6	15u" (0.38um) MIN. GOLD (LUBRICATED)	35u"-100u" Tin PLATING	50u" (1.27um) MIN. NICKEL OVERALL	6B	15u" (0.38um) MIN. GOLD (LUBRICATED)	35u"-100u" Tin/Lead PLATING	50u" (1.27um) MIN. NICKEL OVERALL
7	30u" (0.76um) MIN. GOLD (LUBRICATED)			7B	30u" (0.76um) MIN. GOLD (LUBRICATED)		
8	3u" (0.076um) MIN. GOLD (LUBRICATED)			8B	3u" (0.076um) MIN. GOLD (LUBRICATED)		
2LF	15u" (0.38um) MIN. GOLD	35u"-100u" Tin PLATING	50u" (1.27um) MIN. NICKEL OVERALL				
3LF	30u" (0.76um) MIN. GOLD						
4LF	3u" (0.076um) MIN. GOLD						
6LF	15u" (0.38um) MIN. GOLD (LUBRICATED)	35u"-100u" Tin PLATING	50u" (1.27um) MIN. NICKEL OVERALL				
7LF	30u" (0.76um) MIN. GOLD (LUBRICATED)						
8LF	3u" (0.076um) MIN. GOLD (LUBRICATED)						

COLOR OF HOUSING AN EJECTOR

- 0 : BLACK HOUSING + IVORY EJECTOR
- 1 : BLACK HOUSING + AMBER EJECTOR
- 2 : BLACK HOUSING + BLACK EJECTOR
- 3 : BLUE HOUSING + IVORY EJECTOR
- 4 : BLUE HOUSING + AMBER EJECTOR

- NOTE:
1. MATERIAL:  
 HOUSING: HIGH PERFORMANCE RESINS, GLASS FILLED UL94V-0 RATED, COLOR: BLACK.  
 EJECTOR: HIGH PERFORMANCE RESINS, GLASS FILLED UL94V-0 RATED, COLOR: NATURAL.
  2. TERMINAL: COPPER ALLOY.
  3. FCI LOGO TO BE APPROXIMATELY LOCATED AS SHOWN ON PRINT.
  4. PRODUCT SPECIFICATION: GS-12-273
  5. CARD THICKNESS APPLIES ACROSS TABS AND INCLUDES PLATING AND / OR METALIZATION.
  6. 3.00mm MINIMUM APPLIES TO BOTH 4.00mm WIDE NOTCH LENGTH AND COMPONENT KEEPOUT AREA.
  7. LEADING EDGE OF CONTACT PADS SPECIFIED BY THE KEEP OUT ZONE SHALL BE FREE OF BURRS AND EXTERNAL TIE BARS.  
 FOR OPTIMUM PERFORMANCE, THE TIE BAR IS TO BE ON AN INTERNAL LAYER SO THAT THE REMNANT CANNOT CAUSE CONTACT DAMAGE.
  8. PACKAGING SPECIFICATION: GS-14-528.
  9. ALL PTH SHOULD BE 0.66mm DIA DRILLED AND 0.025mm MIN. ELECTRO-DEPOSITED COPPER THK ON THROUGH HOLE WALL.
  10. THIS PRODUCT MEETS EUROPEAN UNION DIRECTIVES AND OTHER COUNTRY REGULATIONS AS DESCRIBED IN GS-22-008.
  11. THE HOUSING WILL WITHSTAND EXPOSURE TO 260° PEAK TEMPERATURE FOR 20 SECONDS IN A IR REFLOW OVEN.

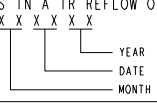

	Title	DDR II 240P PRESS-FIT	dwg no <b>10034542</b>	Rev. <b>P</b>
	catalog	PDM: Rev:P		

CUSTOMER sheet 4 of 4  
 Printed: Jul 28, 2010

Copyright FCI.