

0395

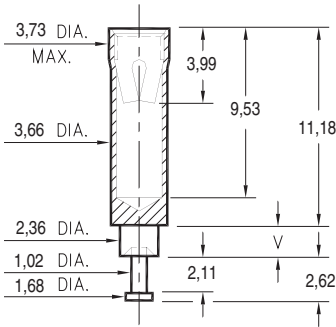

Basic Part Number	Board Thickness	Length V
0395-1	0,79	1,57
0395-2	1,57	2,39
0395-3	2,39	3,18
0395-4	3,18	3,96
0395-5	4,78	5,56

0395-X-15-XX-07-XX-10-0
Swage mount in 2,44 hole

8001

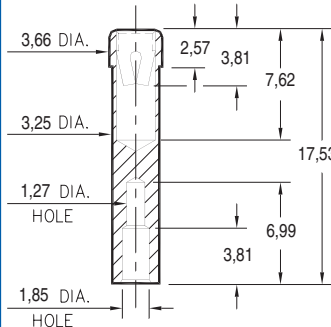

8001-0-19-XX-07-XX-10-0
Wire Termination

8016

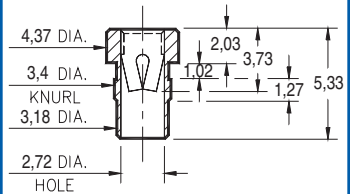

8016-0-15-XX-07-XX-10-0
Press-fit in 3,33 mounting hole

0350

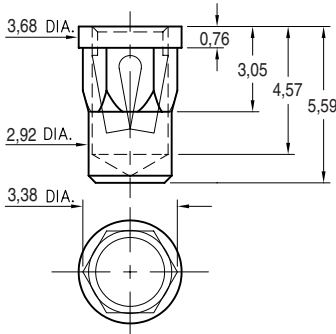

0350-0-15-XX-07-XX-10-0
Hex press-fit in 3,28 ±0,05 plated thru hole

8837

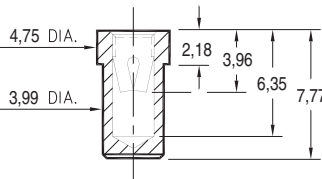

8837-0-15-XX-14-XX-10-0
Solder mount in 4,04 min. mounting hole

SPECIFICATIONS

SHELL MATERIAL:
Brass Alloy 360, 1/2 Hard

CONTACT MATERIAL:
Beryllium Copper Alloy 172, HT

PART MANUFACTURED IN INCHES, METRIC FOR REF ONLY

TOLERANCES ON:
LENGTHS: ± 0,13
DIAMETERS: ± 0,05
ANGLES: ± 2°

ORDER CODE: XXXX - X - 15 - XX - XX - XX - 10 - 0

BASIC PART # →

SPECIFY SHELL FINISH:

- 01 5,08µm TIN/LEAD OVER NICKEL
- 80 5,08µm TIN OVER NICKEL ◊
- 15 0,25µm GOLD OVER NICKEL ◊

SPECIFY CONTACT FINISH:

- 01 5,08µm TIN/LEAD OVER NICKEL
- 80 5,08µm TIN OVER NICKEL ◊
- 27 0,76µm GOLD OVER NICKEL ◊



SELECT CONTACT

#07 or #14 CONTACT (DATA ON PAGE 214 & 215)