

ELECTRICAL

Impedance	50 Ohm constant
Frequency range	0-11 GHz, 1500 V typ.
Voltage Rating 1500 x .707 (1060 rms)	1500 volts peak, std.
Dielectric Withstanding	3000 volts RMS
Voltage VSWR	1500 volt type; 1.35 max. to 11 GHz max. 2 Amps current @ 100 MHz @ 1500 volts peak

ENVIRONMENTAL

Temperature range	-65°C to +165°C
Weatherproof	Except as noted, all C series connectors are weatherproof
Hermetic Seals	Pass helium leak test of 2×10^{-8} c/sec
Pressurized	Compression seal

MECHANICAL

Mating	2-stud Bayonet lock
Cable affixment	Braid clamp

MATERIAL

Contacts	Male: brass Female & Outer beryllium copper. Silver plated except M39012 gold.
Other metal parts	Brass: ASTROplate® finish except M39012 silver
Insulators	TFE, glass-TFE (hermetically sealed)
Weatherproof gaskets	Silicone rubber

MILITARY SPECIFICATIONS

MIL-C-39012 & MIL-A-55339	where applicable
------------------------------	------------------

NOTE: These characteristics are typical and may not apply to all connectors.

PLUG

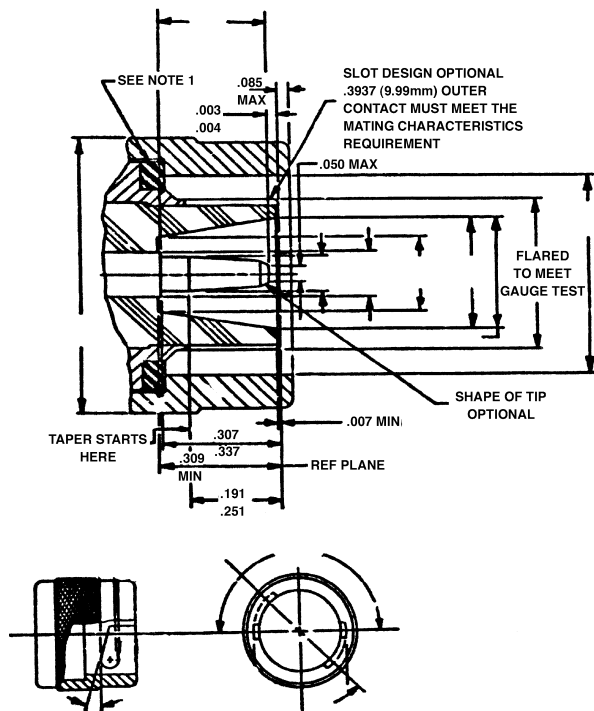

JACK

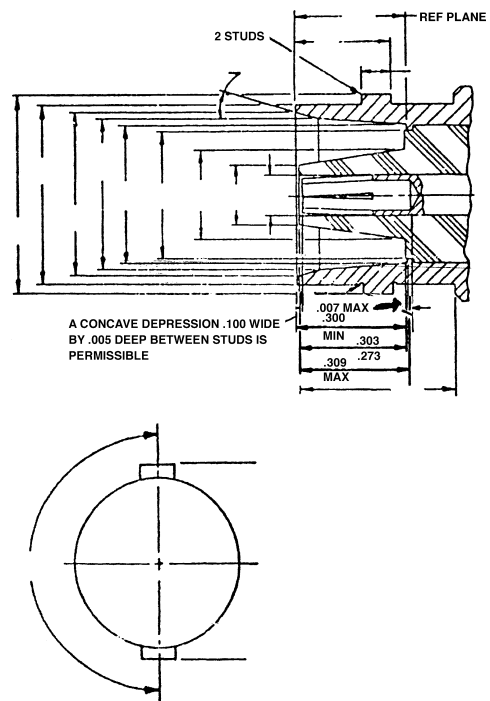

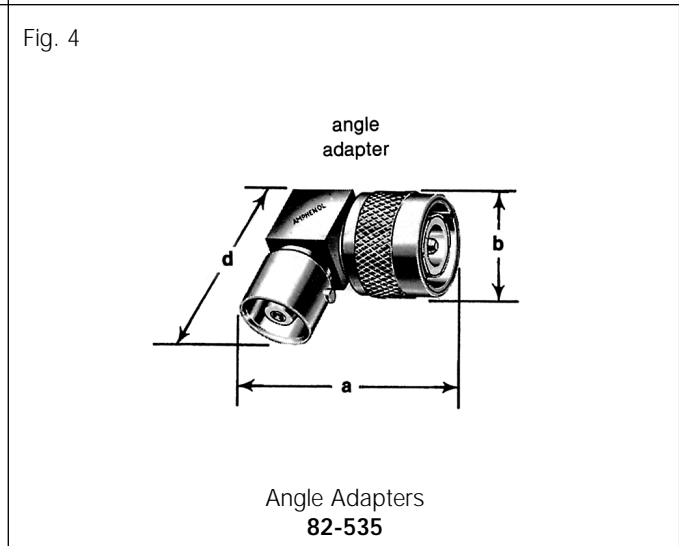
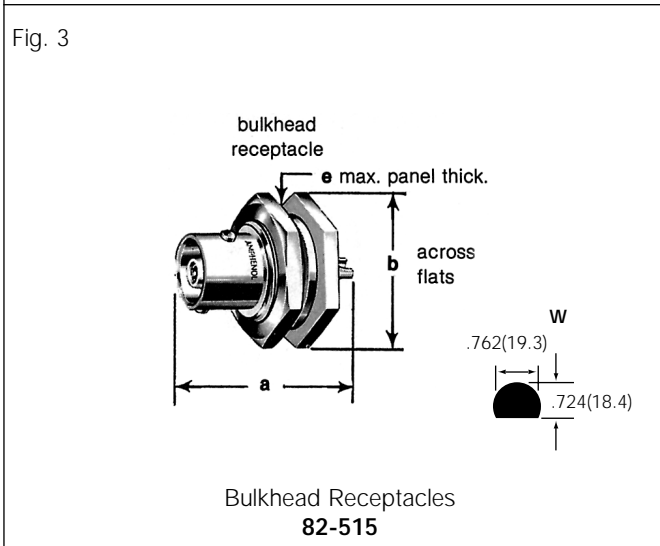
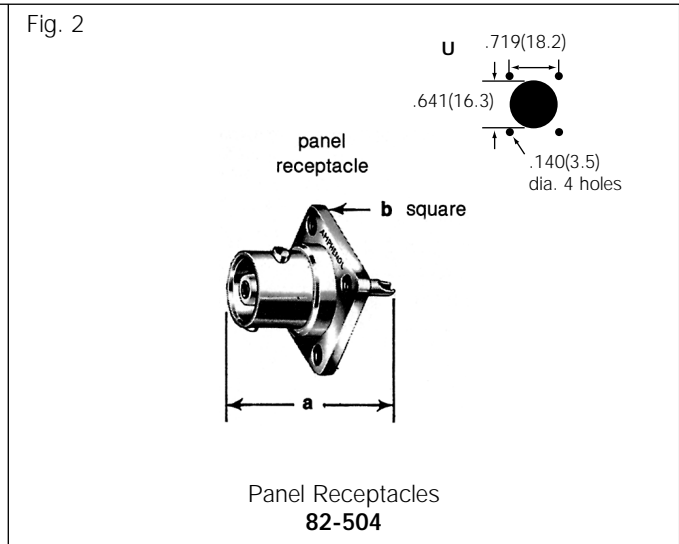
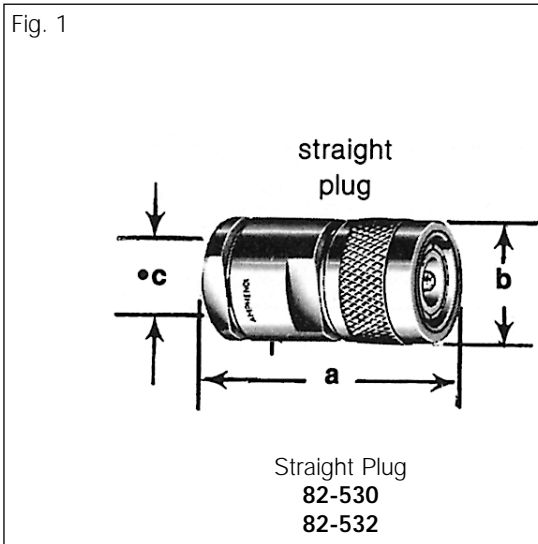

STRAIGHT PLUGS

Cable RG-/U	Dimensions, inches (millimeters)					Construction Notes			Military Number	Amphenol Number	Fig
	a	b	c	d	e	CAI	Plt.	Ins.			
8, 9, 87A, 213, 214, 225	1.48 (37.7)	.750 (19.1)	.444 (11.3)	—	—	C16	P1	D1	UG-573A	82-530	1
	1.75 (44.5)	.750 (19.1)	.444 (11.3)	—	—	C16	P1	D1	UG-628A (4000 V Peak)	82-532	1

PANEL RECEPTACLES

Description	Dimensions, in. (mm)				MTG Hole	Construction Notes			Military Number	Amphenol Number	Fig
	a	b	d	e		CAI	Plt.	Ins.			
#6-32 tapped flange holes/female contacts	1.09 (27.8)	1.00 (25.4)	—	—	U	—	P1	D1	UG-568	82-504	2
4000 volts peak	1.31 (33.3)	1.00 (25.4)	—	1.56 (4.0)	W	—	P1	D1	UG-634	82-515	3

ANGLE ADAPTER

Description	Dimensions, in. (mm)				MTG Hole	Construction Notes			Military Number	Amphenol Number	Fig
	a	b	d	e		CAI	Plt.	Ins.			
Jack-plug/non-weatherproof	1.25 (31.8)	.766 (19.4)	1.25 (31.8)	—	—	—	P4	D1	UG-567A	82-535	4