

1005/1013/8898

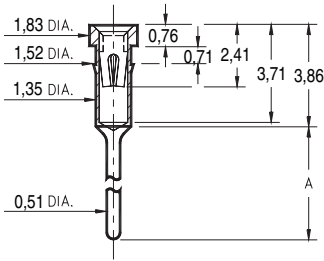

Basic Part Number	Length A
1005-0	3,51
1013-0	4,19
8898-0	5,69

NOTE: 8898 is not annealed & not suitable for auto-clinching

XXXX-0-15-XX-3X-XX-04-0

Press-fit in 1,45 mounting hole
1/4 hard brass shell for auto-clinching

0145/0146

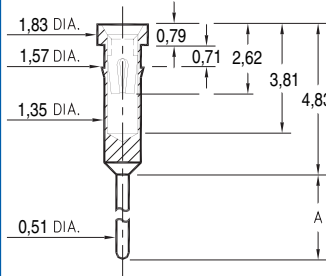

Basic Part Number	Length A
0145-0	7,62
0146-0	10,41

014X-0-15-XX-30-XX-04-0

Press-fit in 1,5 mounting hole

4378

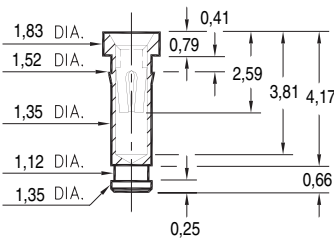

4378-0-15-XX-30-XX-10-0

Press-fit in 1,45 mounting hole

0556

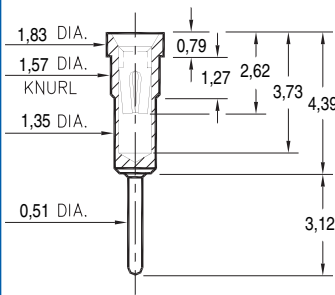

0556-0-15-XX-30-XX-04-0

Press-fit in 1,5 mounting hole

1103

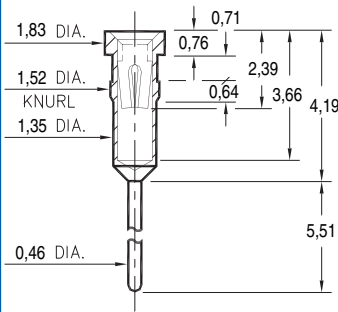

1103-0-15-XX-30-XX-04-0

Press-fit in 1,45 mounting hole

9234

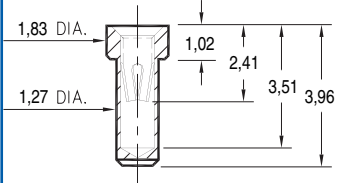

9234-0-15-XX-30-XX-10-0

Solder mount in 1,32 min. mounting hole

0136/37/38/39/41/48/52

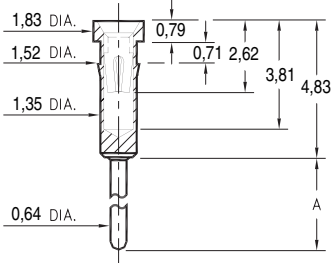

Basic Part Number	Length A
0136-0	30,86
0137-0	14,22
0138-0	5,33
0139-0	16,13
0141-0	17,78
0148-0	11,56
0152-0	10,41

01XX-0-15-XX-30-XX-04-0

Press-fit in 1,45 mounting hole

0447

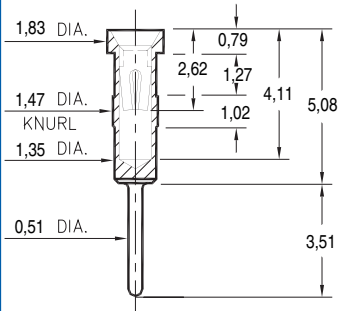

0447-0-15-XX-30-XX-04-0

Press-fit in 1,42 mounting hole

5660

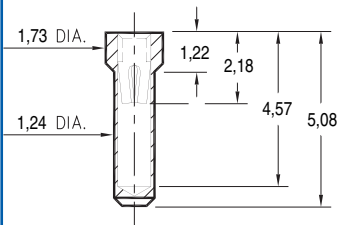

5660-0-15-XX-30-XX-10-0

Solder mount in 1,3 min. mounting hole

SPECIFICATIONS

SHELL MATERIAL:
Brass Alloy 360, 1/2 Hard

CONTACT MATERIAL:
Beryllium Copper Alloy 172, HT

PART MANUFACTURED IN INCHES, METRIC FOR REF ONLY

TOLERANCES ON:
LENGTHS: ± 0,13
DIAMETERS: ± 0,05
ANGLES: ± 2°

ORDER CODE: **XXXX - X - 15 - XX - 3X - XX - XX - 0**

BASIC PART # →

SPECIFY SHELL FINISH:

- 01** 5,08µm TIN/LEAD OVER NICKEL
- 80** 5,08µm TIN OVER NICKEL ◊
- 15** 0,25µm GOLD OVER NICKEL ◊

SPECIFY CONTACT FINISH:

- 02** 2,54µm TIN/LEAD OVER NICKEL
- 84** 2,54µm TIN OVER NICKEL ◊
- 27** 0,76µm GOLD OVER NICKEL ◊



SELECT CONTACT

#30 or #32 CONTACT (DATA ON PAGE 208)