

Tolerances unless otherwise specified		
linear	.X	±0.38
	.XX	±0.25
	.XXX	±0.13
angles	X°	±2°

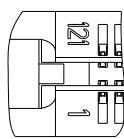

DETAIL A
SCALE 3.000

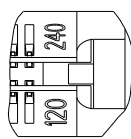

DETAIL B
SCALE 3.000

Mark with WITH_OPEN_LATCH REV. E in area indicated by X.....		Material * Mat code Heat treat Plating/Finish	Spec ref * Tolerance ✓ projection MM size A4 Scale 1.000
Dr RICHARD CHIU 01/11/05 Eng RICHARD CHIU 01/11/05 Chr PAUL WANG 01/11/05 Appr JOSEPH HSIA 01/11/05	Product family Model Name WITH_OPEN_LATCH Model Revision 1	ECN DG06-0506 REL Level RELEASED	Rev. E
rev ecn no dr date A DG06-0047 WK 02/13/06 B DG06-0093 CS 03/06/06 C DG06-0506 CS 12/05/06 D DG06-0547 CS 12/21/06 E DG07-0194 CS 15/05/07		FCI title DDR1 VERY LOW PROFILE SOCKET ASSEMBLY	dwg no 10052286 CUSTOMER STATUS Released sheet 1 of 4

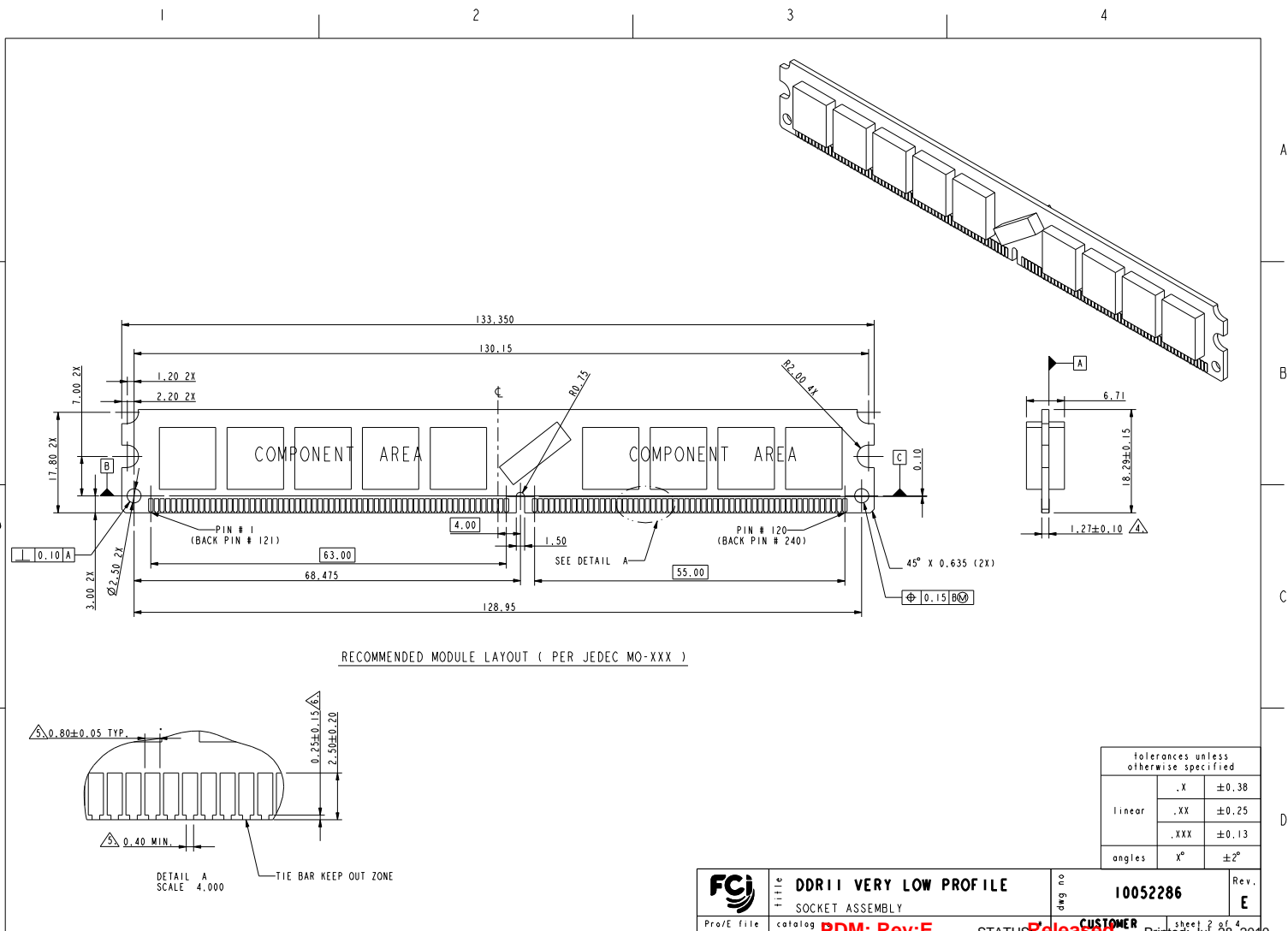

FCI Pro/E title	title	DDR1 VERY LOW PROFILE SOCKET ASSEMBLY	dwg no 10052286	Rev. E
	catalog	PDM: Rev:E		

STATUS Released Printed: Jul 28, 2010

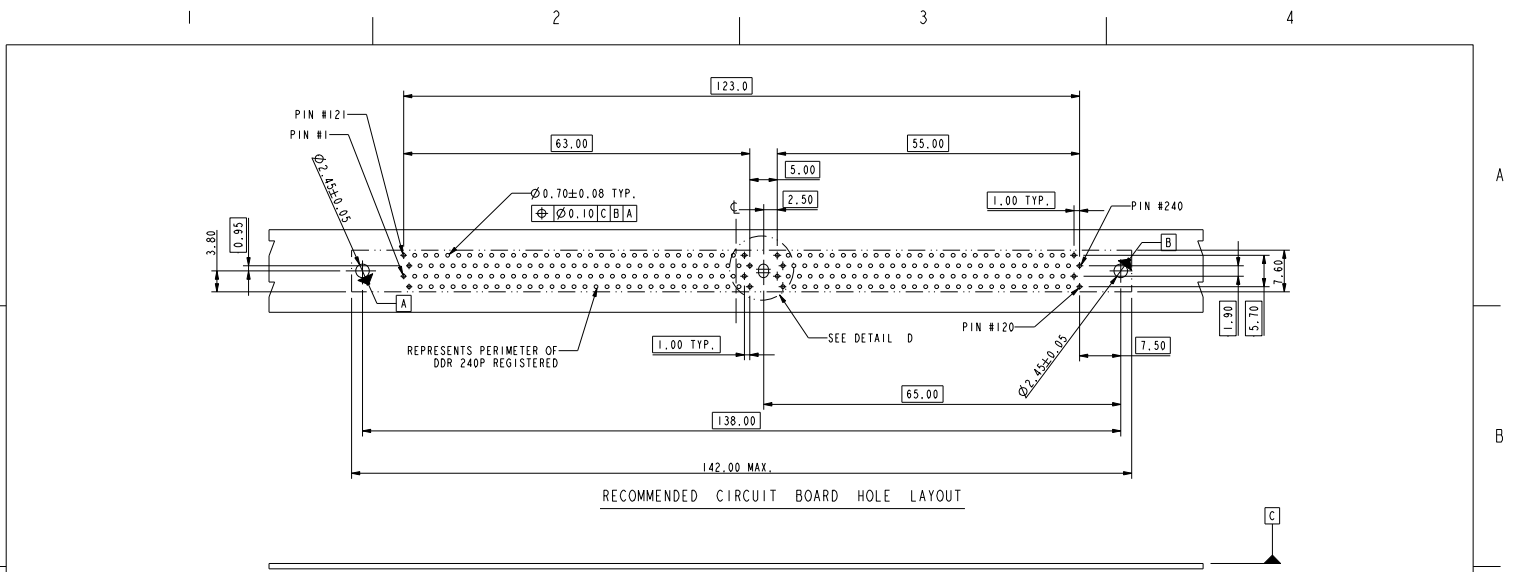

DETAIL D
SCALE 4.000

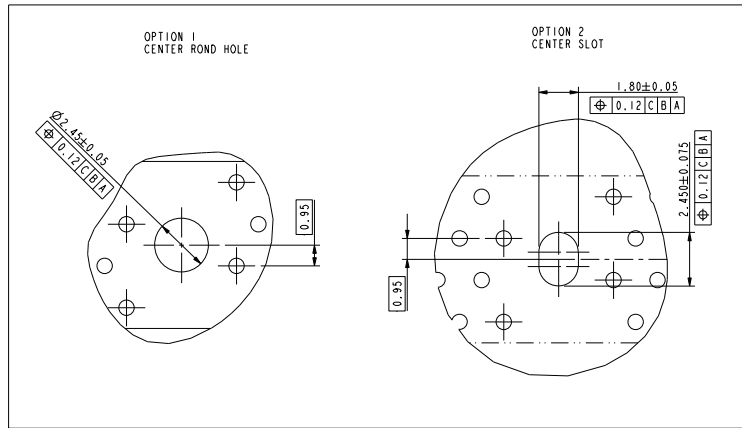

REV C 2006-04-11

Tolerances unless otherwise specified		
linear	.X	± 0.38
	.XX	± 0.25
	.XXX	± 0.13
angles	X°	$\pm 2^\circ$

	title	DDR11 VERY LOW PROFILE SOCKET ASSEMBLY	dwg no 10052286	Rev. E
	Prof/E title catalog	PDM: Rev:E STATUS: Released		

Printed: Jul 28, 2010



10052286 - □ □ □ □ □

STYLE : MECHANICAL KEYING

- 1 : 1,8 VOLT. W/TYPE "C"
- 2 : 2,5 VOLT. W/TYPE "L"
- 3 : X.X VOLT. W/TYPE "R"

METAL CLIP

- 1 : WITH METAL CLIP + DIM."D"=3.05
- 2 : WITH METAL CLIP + DIM."D"=3.56
- 3 : WITH METAL CLIP + DIM."D"=3.43

TAIL LENGTH

CODE	DIM. "B"	PCB THICKNESS
0	2.54	1.47 mm (0.058")
1	2.67	1.60 mm (0.063")
2	3.18	2.36 mm (0.093")
3	4.00	3.18 mm (0.125")

PLATING

CODE	CONTACT	SOLDERTAIL	UNDERPLATE
2	15 u" (0.38um) MIN. GOLD	100u" (2.54um) MIN. TIN/LEAD	50u" (1.27um) MIN. NICKEL OVERALL
3	30u" (0.76um) MIN. GOLD		
4	3u" (0.076um) MIN. GOLD		
7LF	15u" (0.38um) MIN. GOLD	100u" (2.54um) MIN. 100% TIN	50u" (1.27um) MIN. NICKEL OVERALL
8LF	30u" (0.76um) MIN. GOLD		
9LF	3u" (0.076um) MIN. GOLD		

COLOR OF HOUSING AND EJECTOR

- 0 : BLACK HOUSING + IVORY EJECTOR
- 1 : BLUE HOUSING + IVORY EJECTOR
- 2 : BLACK HOUSING + BLACK EJECTOR

NOTES:

1. MATERIAL:
HOUSING: HIGH PERFORMANCE RESINS, GLASS FILLED UL94V-0 RATED.
EJECTOR: HIGH PERFORMANCE RESINS, GLASS FILLED UL94V-0 RATED.
TERMINAL: PHOSPHOR BRONZE.
METAL CLIP: COPPER ALLOY.
2. FCI LOGO TO BE APPROXIMATELY LOCATED AS SHOWN ON PRINT.
3. PRODUCT SPECIFICATION: GS-12-352.
- ⚠️ CARD THICKNESS APPLIES ACROSS TABS AND INCLUDES PLATING AND/OR METALIZATION.
- ⚠️ LEADING EDGE OF CONTACT PADS SPECIFIED BY THE KEEP OUT ZONE SHALL BE FREE OF BURRS AND EXTERNAL TIE BARS. FOR OPTIMUM PERFORMANCE, THE TIE BAR IS TO BE ON AN INTERNAL LAYER SO THAT THE REMNANT CANNOT CAUSE CONTACT DAMAGE.
6. THIS PRODUCT MEETS EUROPEAN UNION DIRECTIVES AND OTHER COUNTRY REGULATIONS AS DESCRIBED IN GS-22-008.
7. THE HOUSING WILL WITH STAND EXPOSURE TO 260°C PEAK TEMPERATURE FOR 10 SECONDS IN A WAVE SOLDER APPLICATION.
8. DATE CODE:XXXXXX* MEANS MONTH/DAY/YEAR.
"*" MEANS PRODUCTION LINE CODE.

	DDR11 VERY LOW PROFILE		dwg no 10052286	Rev. E
	SOCKET ASSEMBLY			
Pro/E file	catalog	PDM: Rev:E	STATUS Released	CUSTOMER
			sheet 4 of 4	Printed: Jul 28, 2010